

# **CSE-6100<sup>TM</sup>**

**1D/2D Barcode Miniature Engine**

**OPERATION Manual**



**에스엠클레버**

**Second Edition  
August, 18, 2012**



## About CODESQUARE

CODESQUARE is a leading Korean developer and manufacturer of 1D/2D barcode reader products & solutions, ultimately pursuing total solution provider of 2D barcode reader products including hardware, software, OEM & ODM businesses and etc.

We are committed to providing our customers with reliable and innovative products at the competitive cost. 2D barcode reader products are our new products released by our own proprietary 2D barcode engine and algorithm. Various barcode readers and applications including Bluetooth reader and 2D barcode reader module + finger print recognition feature are to be released soon.

Quality is our top priority among our missions. 6 sigma quality program and ISO- 9001 certified processes make us enabling to meet the industry and international quality standards in all areas including product design, manufacturing, testing, inspection, shipping and customer services, leveling up our capability of comprehensive quality control of products manufactured in the factory and providing all employees with quality training and education for their better job undertaking and responsibility & authorization to continually improve products and services in their areas.

In the fast growing communication industries, we are requested to be prepared for more and more expanding customer requirements to new innovative quality products and services.

CODESQUARE's achievements in the future will be made by our continued Research & Development, timely preparedness for the new technologies and the hard works of dedicated people to the customers.

## Contact Information

✉ **Email** – [esmclever@gmail.com](mailto:esmclever@gmail.com) , [hjs@smclever.com](mailto:hjs@smclever.com)

☎ **Phone No.** - 82-2-2065-0300

☎ **FAX No.** - 82-2-2065-0380

📍 **Address** – #B1 3-1, VIP Bldg., Hwagok 6-dong, Gangseo-gu, Seoul, Korea

🌐 **URL** : <http://www.smclever.com>

## Regulations

### FCC Statement

This equipment has been tested and found to comply with the limits for a Class A digital device pursuant to part 15 of the Federal Communications Commissions (FCC) Rules. These limits are designed to provide reasonable protection against harmful interference in a commercial environment. This equipment generates, uses, and can radiate radio frequency energy and, if not installed and used in accordance with this manual, may cause harmful interference to radio communications. If this equipment does cause harmful interference, users can be determined by turning the equipment off and on.

### CE Statement

This equipment has been tested and complies with EN55022, EN55024, EN61000-3-2 and EN61000-3-3.

### MIC Statement

Korean Ministry of Information and Communication (MIC) statement.

Please note that this device has been certified for business use with regard to electromagnetic interface.

### RoHS Statement

This lead free and halogen free product is fully RoHS compliant, meeting the European Parliament Directive entitled "Restrictions on the use of Hazardous Substances" (RoHS).

### WEEE Compliance Statement for European Community Users.

This product complies with Directive 2002/69/EC of the European Parliament and of the council of 27 January 2003 on waste electronic equipment (WEEE).

### Laser Aimer Eye Safety - Class 2 Category

The CSE-6100™ is Class 2 level of laser power output to standard IEC 60825-1:2001 first edition.



The CSE-6100™ can be set to use targeting lasers. If the targeting lasers are activated, do not stare into the beams.

## Table of Contents

<b>1. Before you start .....</b>	<b>5</b>
1.1. Overview of CSE-6100™ .....	5
1.2. Unpacking information .....	5
1.3. Connecting the scanner to serial port (for SDK) .....	5
1.4. Connecting the scanner to USB port (for SDK) .....	5
1.5. Installation and operation of CSE-6100™ .....	6
1.6. Barcode reading .....	6
<b>2. CSCenter™ .....</b>	<b>7</b>
2.1. Startup of CSCenter™ .....	7
2.2. Title Bar .....	7
2.3. Display of main window .....	7
2.4. Barcode & System Setup .....	9
2.4.1. System Setup .....	9
2.4.2. Serial Port Setting .....	11
2.4.3. 2D (PDF-417, microPDF-417 Setup) .....	12
2.4.4. 2D (QR, Data Matrix, AZTEC, MAXI Code) Setup .....	13
2.4.5. UPC, EAN/JAN Setup .....	14
2.4.6. ITF, STF, Matrix 2of5, IATA 2of5, Chinese Post Setup .....	15
2.4.7. Code39, Code11, MSI Setup .....	16
2.4.8. Code93, Code128, GS128, Korean Post Setup .....	17
2.4.9. Codabar, Telepen Setup .....	18
2.4.10. GS1 DataBar, Composite Code Setup .....	19
<b>3. Camera Setup .....</b>	<b>20</b>
<b>4. Application Interface .....</b>	<b>21</b>
<b>5. Firmware Update .....</b>	<b>22</b>
<b>6. Command summary .....</b>	<b>24</b>
<b>7. Configuring using barcodes.....</b>	<b>31</b>
7.1. Start, Save & Exit .....	31
7.2. Communications .....	31
7.3. System .....	34
7.4. 2D barcode symbologies .....	39
7.5. 1D barcode symbologies .....	41
7.6. Composite Code .....	54
7.7. LED control .....	55
7.8. Scan mode (Direct Operation) .....	56
<b>8. Data Transmission format .....</b>	<b>57</b>
<b>9. Code ID Table.....</b>	<b>59</b>
<b>10. ASCII conversion chart (Code Page 1252) .....</b>	<b>60</b>
<b>11. Hex &amp; ASCII table.....</b>	<b>61</b>
<b>12. CSE-6100™ Specification Sheet.....</b>	<b>62</b>
<b>13. Maintenance.....</b>	<b>63</b>
13.1. CSE-6100™ Attentive Points for Using .....	63
13.2. Problem appearance .....	63
13.3. Frequent Problem Solving .....	63
<b>14. Interface cable for SDK.....</b>	<b>64</b>
14.1. CSE-6100™-RS232C .....	64
14.2. CSE-6100™-USB/HID .....	65
<b>15. Host interface for SDK (RS232C / USB).....</b>	<b>66</b>
<b>16. FPC Connector Signal Descriptions.....</b>	<b>68</b>
<b>17. Engine &amp; SDK Drawing .....</b>	<b>69</b>
<b>18. SDK Schematic Diagram.....</b>	<b>69</b>
<b>18. SDK Schematic Diagram.....</b>	<b>70</b>

## 1. Before you start

### 1.1. Overview of CSE-6100™

CSE-6100™ is new small 2D barcode handheld scanner.

This miniature engine enables customers to fast and reliably integrate 2D barcode decoding solutions into target systems and hardwares. This engine subject to be provided as software to customers with the same features and benefits of handheld scanner products.

### 1.2. Unpacking information

The CSE-6100™ is shipped in a gift box and should contain:

Model Name	Engine	FPC Cable	SDK	RS232C Cable	Power Supply
CSE-6100-	●	●			
CSE-6100-SDK	●	●	●	●	●

### 1.3. Connecting the scanner to serial port (for SDK)

By default, the CSE-6100™ connects to an RS232C interface.

The CSE-6100™ uses the DB9 connector with external power adapter for RS232C interface.

1. Power the host (terminal or computer) off.
2. Connect the RS232C interface cable to the scanner.
3. Connect the power adapter plug in the power supply. The scanner will beep twice.
4. Connect the RS232C cable to the host.
5. Power the host on.

Now CSE-6100™ has been connected and ready to communicate with host.

### 1.4. Connecting the scanner to USB port (for SDK)

The CSE-6100™ supports USB interface for USB or HID version. It's fully compatible with the specifications of USB1.1. External power adapter is not used on this USB mode.

1. Power off the host (terminal or computer).
2. Connect the USB interface cable to the scanner.
3. Connect the USB cable to the host.
4. Power on the host.

## 1.5. Installation and operation of CSE-6100™

### Program and USB Driver auto-Installation:

All programs is copy to user directory or use to install program as followings;

1. Use Install CD or download it from our web site at [www.dslna.com](http://www.dslna.com).
2. Double click on the **Setup.exe** file and follow the screen prompts to install the program.
3. Program is saved to user directory. Default directory is "Program Files\CSCenter".
4. Programs saved on your directory are as follows;
  - ① CSCenter.exe is a MS Windows program that sets up the CSE-6100™ scanner and displays decoded symbol data, capturing images from the scanner. It supports RS232C and USB.
  - ② \*.Inf and \*.sys files: USB device driver for CSE-6100™ USB scanner.
  - ③ CSE-6100™ user's guide.pdf: User Manual

### Confirm the Driver Installation:

If your system comes with physical COM port, then it will occupy the COM1 and even COM2 if your system has two. After USB-Serial Bridge driver is installed, it will create a virtual COM port and the default setting by the OS is the COM2 or COM3 if there are two physical COM ports on your system. If you want to change the COM3 created by USB-Serial Bridge to the COM1, follow these steps:

1. Double click My Computer, Control Panel, System
2. Click Device Manager tab.
3. Click "Ports (COM & LPT)".
4. See the "CODESQUARE USB Barcode Scanner (COM3)" item
5. Remember this Serial Port Number. (COM3).

## 1.6. Barcode reading

The CSE-6100™ will decode barcodes at any direction. For a good result, refer to following step and diagram.

1. Move the aiming position to the center of the barcode.
2. Keep pressing the trigger (capture) button and do not release until getting result.
3. The CSE-6100™ will continuously capture and decode for a good result.
4. If the result is good, you will have blue LED with one short beep.
5. If the result isn't good, you will have red LED with two beeps.

- ◆ The length of the laser aimer means image capture area.

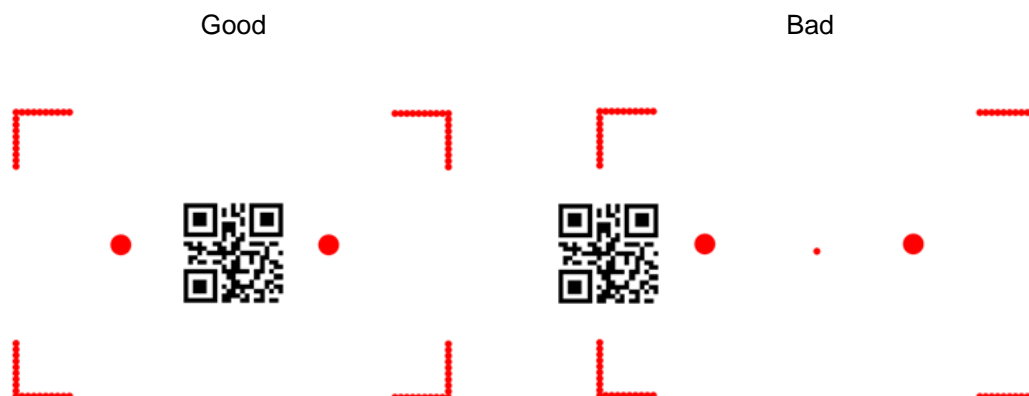

## 2. CSCenter™

CSCenter™ is used to Barcode Setup Program. CSCenter™ displays decoded barcode symbol messages and captures images from CSE-6100™.

### 2.1. Startup of CSCenter™

Before running the CSCenter™, please check the connection of your CSE-6100™ with cable and power.

### 2.2. Title Bar

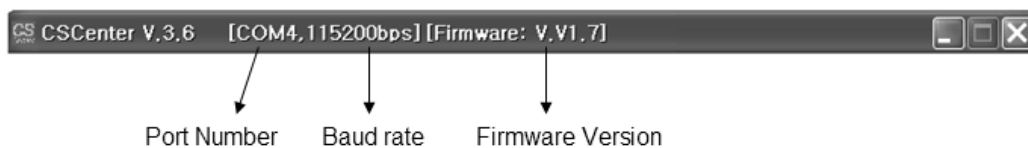

Display the serial port number / baud rate and firmware version of the scanner.

### 2.3. Display of main window

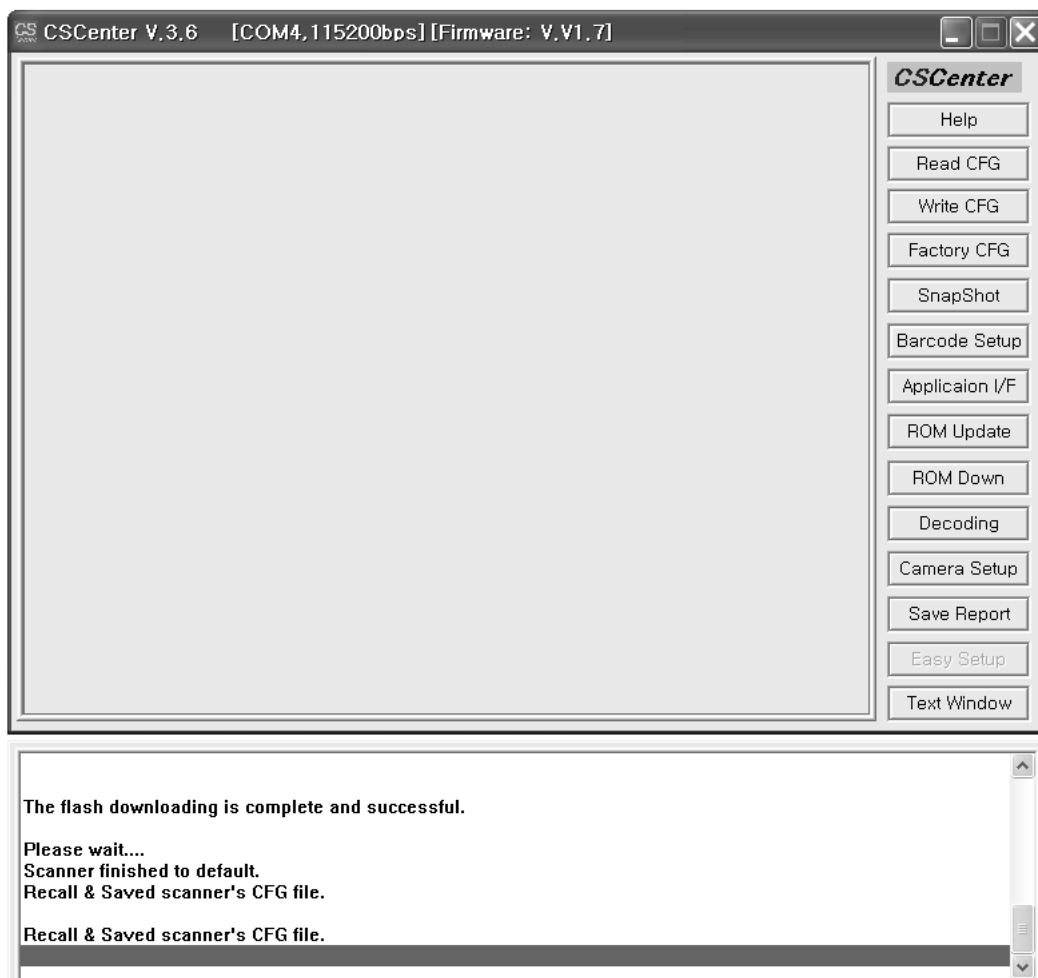

<b>Preview Window</b>	Image Preview Window.
<b>Text Window</b>	Display the decoding result or scanner status display area.
<b>Read CFG</b>	Read parameter saved in scanner for reconfiguration of CSCenter™.
<b>Write CFG</b>	Saves parameter changed on scanner's ROM. Without this step, the changed Configuration is not saved after power-off.
<b>Factory CFG</b>	Change all parameters to factory default setting and saved to scanner. This is not changed to Port Setting Parameters on current setting.
<b>Snapshot</b>	Uploads image from scanner to CSCenter™. (Use to F2 key)
<b>Barcode Setup</b>	Refer to "System & Barcode Setup"
<b>Application I/F</b>	Refer to "Application I/F"
<b>ROM Update</b>	Refer to "ROM Update"
<b>ROM Down</b>	Refer to "ROM Down"
<b>Decoding</b>	Sends scanner the command of capture and decode. Scanner executes the capturing and decode command. (Use to F1 key)
<b>Camera Setup</b>	Refer to "Camera Setup".
<b>Save Report</b>	Saves the active text data to REPORT.txt in C:\CSCenter directory.
<b>Text Window</b>	Text split window on/off button.
<b>Others (F3 Key)</b>	Saves the active bitmap data to the file with auto-file name. (i.e. FILE000.bmp, FILE001.bmp ~ FILE999.bmp or jpg)



## 2.4. Barcode & System Setup

### 2.4.1. System Setup

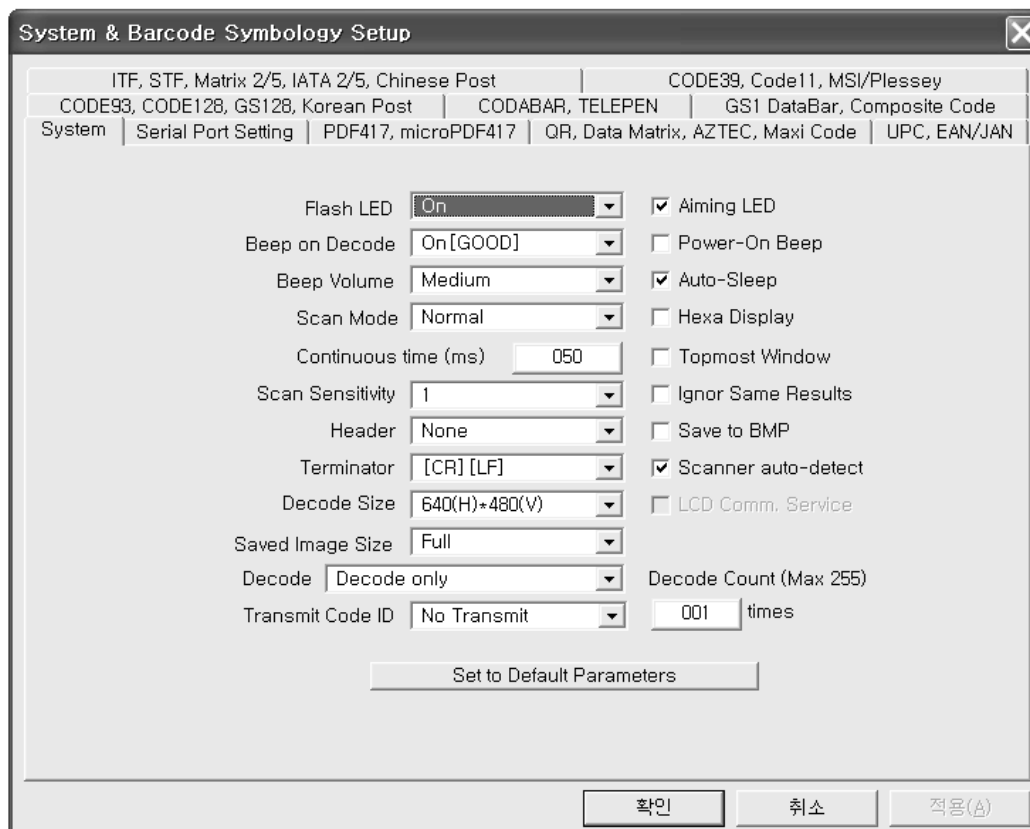

#### Flash LED

Select to flash LED operation.

- Off : Keep LED off at image capture operation.
- On : Keep LED on at image capture operation.
- Auto : Auto controlled LED operation according to the external environment.
- On/Off : LED on/off operation at image capture operation.

#### Beep on Decode

When decoding, enable or disable sound for error or good result..

Operating mode is Off / On / On[NG} / On[GOOD]

#### Beep Volume

Adjust beep volume to Off / Low / Medium / High.

#### Scan Mode

Set to Normal / Auto / Continuous scan mode.

- Normal Scan Mode: Manual and trigger modes. Use trigger button or F1 key (Serial command) operation.
- Auto Scan Mode: Object detection mode. No trigger button operation. This Mode uses object detection method. The LED light will keep turned off until any change occurs in the imager's field of view. When object detect, the LED light will automatically turned on to read the code. If the light condition in the room is not bright enough, This Mode may not work properly
- Continuous Scan Mode: Time interval decoding mode.

**Continuous time (ms)**

Set to time interval value for Continuous Scan Mode. (Min. 50ms, Max 900ms, unit 50ms)

**Header**

Set communication header to None, STX, ESC

**Terminator**

Set communication header to [None], [ETX], [ETX][CR], [CR][LF], [CR], [CR][TAB], [TAB][CR]

**Decode Size**

Select the decoding resolution. (640H \* 480V or 720H \* 480V).

Default is 640H \* 480V.

**Saved Image Size**

Selects the resolution you wish to use for image. (Support to full resolutions only).

**Decoding**

- Decode Only: Decoding only operation.
- with Upload Image if OK : If decoding is good. Decoded image is sent to host.
- with Upload Image if NG : If decoding is fail. Decoded image is sent to host.

**Transmit Code ID**

Two types of Code ID marks are available to No Transmit, Transmit to Simple, Transmit to AIM. Refer to "Code ID Table". (Default is No Transmit)

**Decoding Count**

When use the F1 key or use the host capture & decoding command, sets the number of decoding cycle. Default value is 1 and max. value is 999.

**Aiming LED**

Laser aiming On / Off.

**Power-On Beep**

Set to power-on beep enable/disable.

**Auto-Sleep**

Scanner is default-set to be powered off after 1 minutes of inactivity. If you wish to keep the scanner powered on, select this mode to Off state.

**Hexa Display**

Decoding result is displayed as a hexadecimal.

**Topmost Window**

CSCenter™ is displayed to the topmost windows.

**Ignore Same Results**

Same decoding result is not send to host.

**Save to BMP**

BMP / JPG file selection. (Saved image file format selection)

**Set to Default Parameters**

Set system parameters to factory default setting.

## 2.4.2. Serial Port Setting

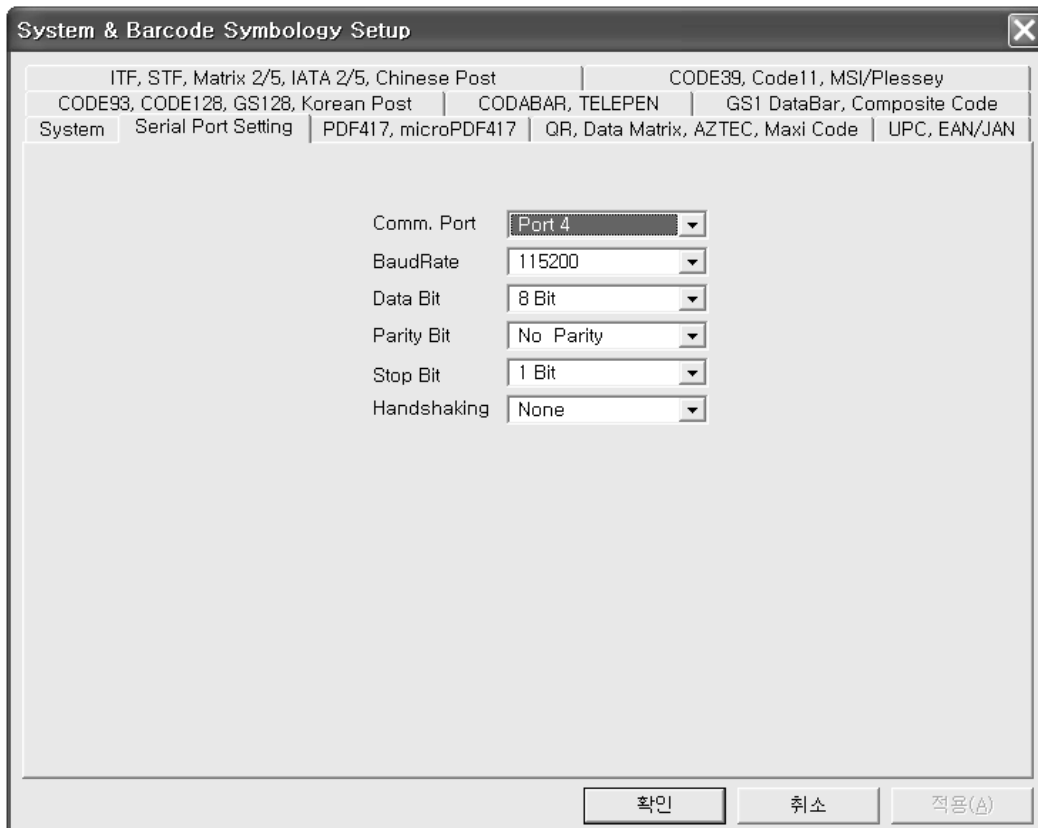

**System & Barcode Symbology Setup**

ITF, STF, Matrix 2/5, IATA 2/5, Chinese Post | CODE39, Code11, MSI/Plessey  
 CODE93, CODE128, GS128, Korean Post | CODABAR, TELEPEN | GS1 DataBar, Composite Code  
 System | **Serial Port Setting** | PDF417, microPDF417 | QR, Data Matrix, AZTEC, Maxi Code | UPC, EAN/JAN

Comm. Port: Port 4  
 BaudRate: 115200  
 Data Bit: 8 Bit  
 Parity Bit: No Parity  
 Stop Bit: 1 Bit  
 Handshaking: None

확인 취소 적용(Alt)

<b>Comm. Port</b>	Select serial port 1 to port 32
<b>Baud rate</b>	Select baudrate. 1,200 / 2,400 / 4,800 / 9,600 / 19,200 / 38,400 / 57,600 / 115,200 / 460,800(USB) / 614,400(USB) bps support.
<b>Data Bit</b>	5,6,7,8 bits
<b>Parity Bit</b>	No/Odd/Even
<b>Stop Bit</b>	1, 2 bit
<b>Handshaking</b>	None, XON/XOFF, RTS/CTS.

### 2.4.3. 2D (PDF-417, microPDF-417 Setup

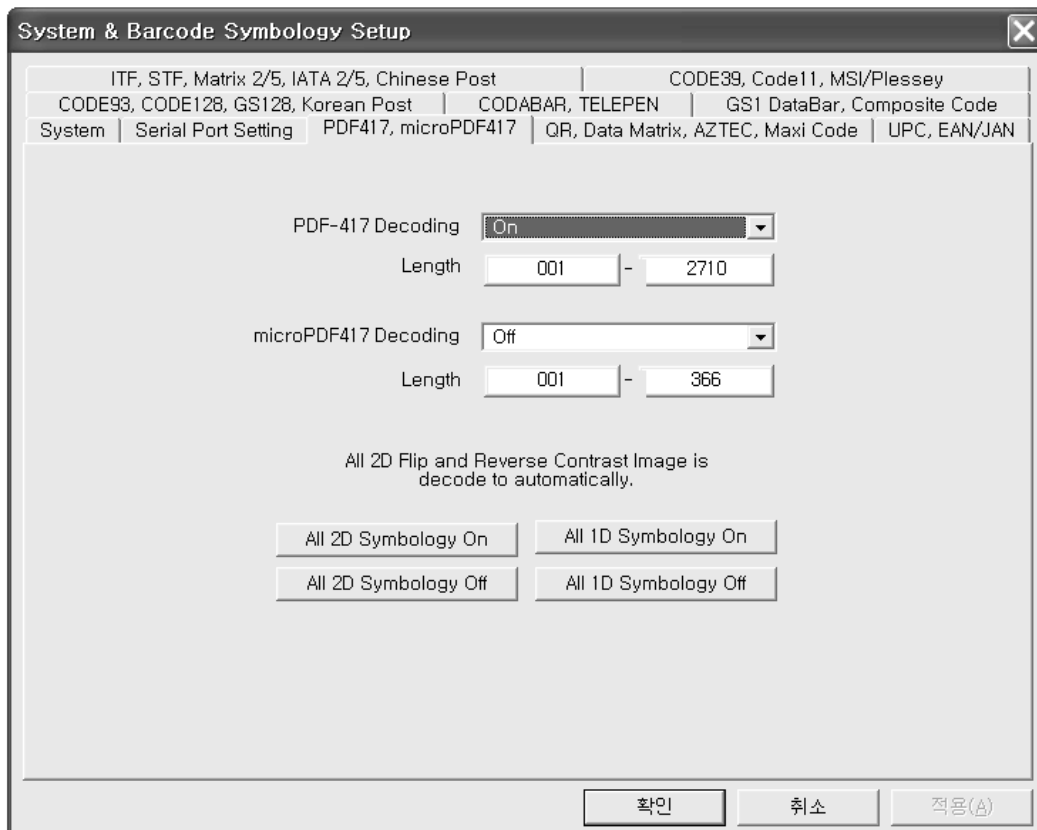

System & Barcode Symbology Setup

ITF, STF, Matrix 2/5, IATA 2/5, Chinese Post | CODE39, Code11, MSI/Plessey  
 CODE93, CODE128, GS128, Korean Post | CODABAR, TELEPEN | GS1 DataBar, Composite Code  
 System | Serial Port Setting | PDF417, microPDF417 | QR, Data Matrix, AZTEC, Maxi Code | UPC, EAN/JAN

PDF-417 Decoding: On  
 Length: 001 - 2710

microPDF417 Decoding: Off  
 Length: 001 - 366

All 2D Flip and Reverse Contrast Image is decode to automatically.

All 2D Symbology On | All 1D Symbology On  
 All 2D Symbology Off | All 1D Symbology Off

확인 | 취소 | 적용(Δ)

- PDF-417 Decoding On / Off and data length setting.
- MicroPDF417 Decoding On / Off and data length setting.
- All 2D Symbology On / Off button
- All 1D Symbology On / Off button

## 2.4.4. 2D (QR, Data Matrix, AZTEC, MAXI Code) Setup

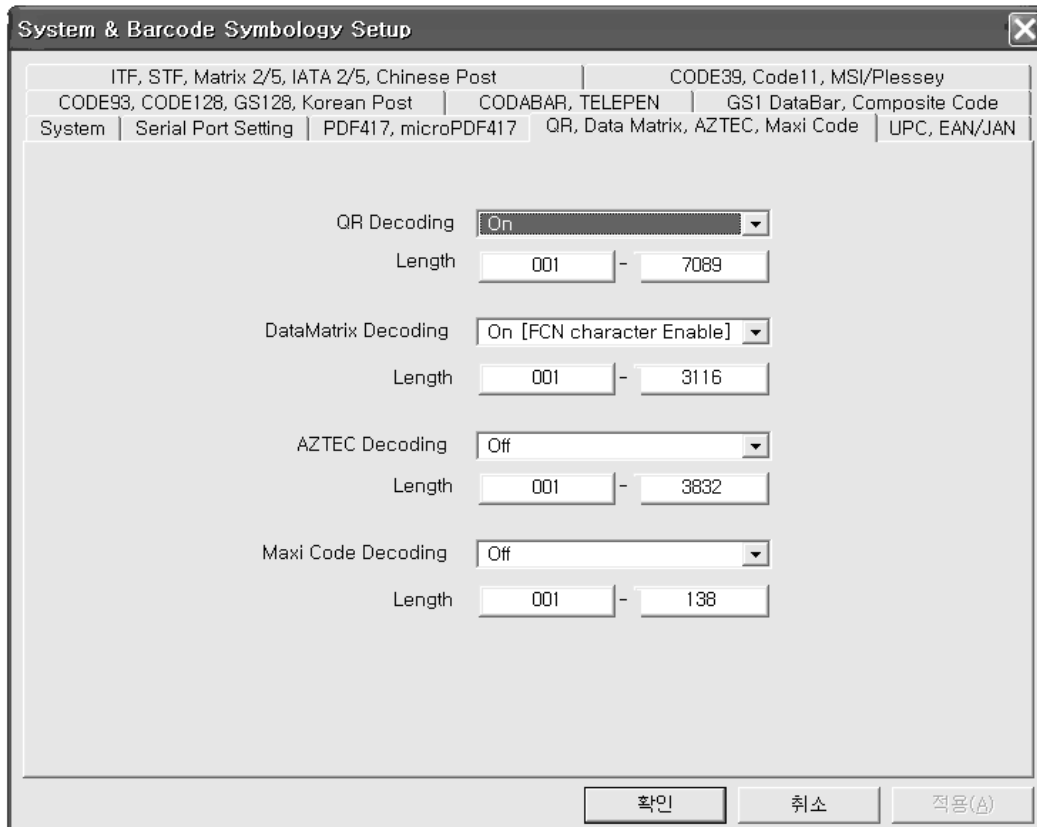

System & Barcode Symbology Setup

ITF, STF, Matrix 2/5, IATA 2/5, Chinese Post | CODE39, Code11, MSI/Plessey  
 CODE93, CODE128, GS128, Korean Post | CODABAR, TELEPEN | GS1 DataBar, Composite Code  
 System | Serial Port Setting | PDF417, microPDF417 | QR, Data Matrix, AZTEC, Maxi Code | UPC, EAN/JAN

QR Decoding: On  
 Length: 001 - 7089

DataMatrix Decoding: On [FCN character Enable]  
 Length: 001 - 3116

AZTEC Decoding: Off  
 Length: 001 - 3832

Maxi Code Decoding: Off  
 Length: 001 - 138

확인 취소 적용(A)

- QR Decoding On / Off and data length.
- DataMatrix Decoding
  - ① Off
  - ② On (FCN character Enable) : with FCN1 Character(0x1D).
  - ③ On (FCN character Disable) : without FCN1 Character(0x1D).
- AZTEC Decoding On / Off and data length.
- Maxi Code Decoding On / Off and data length.

## 2.4.5. UPC, EAN/JAN Setup

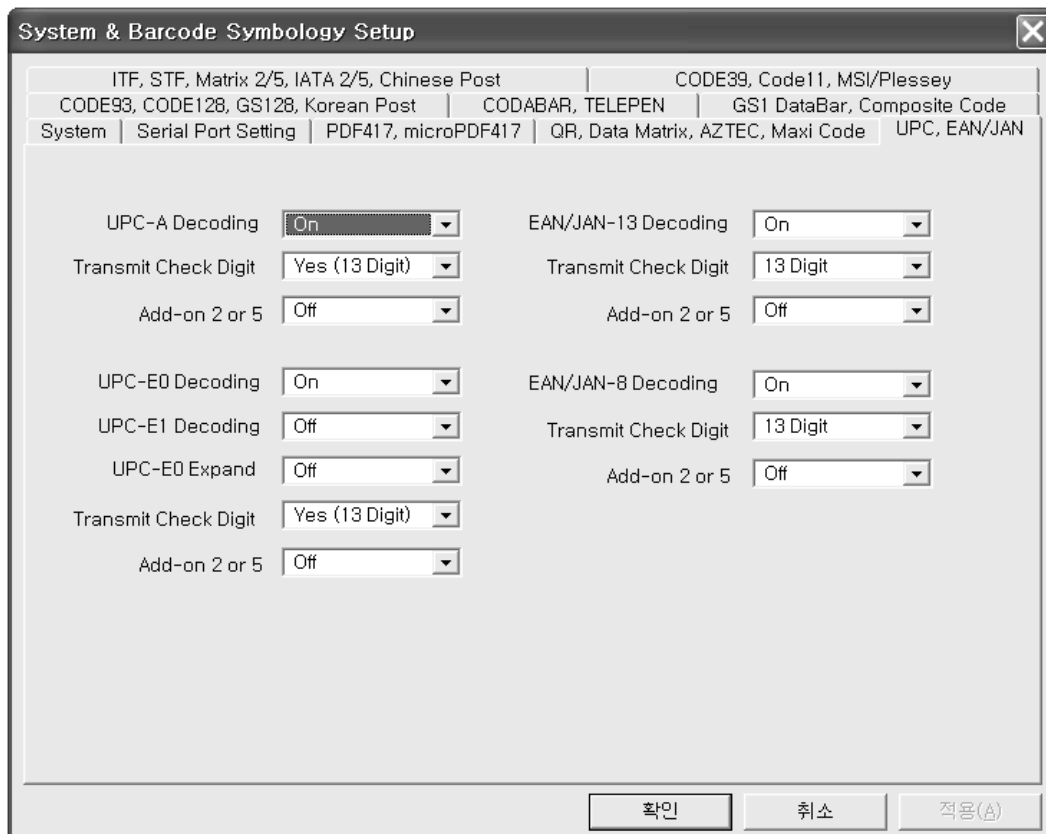

Set to Universal Product Code (UPC) / European Article Numbering (EAN) and Japan Article Numbering (JAN).

### UPC-A

- UPC-A Decoding: Default is On.
- Transfer Check Digit: Default is check digit and transmits.
- Add-on 2 or 5: Default is Off. When enable, add 2 or 5 digits at the end of all decoded data.

### UPC-E0/E1

- UPC-E0 Decoding: Default is On.
- UPC-E1 Decoding: Default is Off.
- UPC-E0 Expand: Default is Off. Expands the UPC-E code to the 12 digit, UPC-A format.
- Transfer Check Digit: Default is check digit and transmits.
- Add-on 2 or 5: Default is Off. When enable, add 2 or 5 digits at the end of all decoded data.

UPC-E0 first digit is always a '0' and UPC-E1 first digit is a '1'.  
An option for UPC-E0 affects UPC-E1 too.

### EAN/JAN-8/13

- EAN/JAN-8/13 Decoding: Default is On.
- Transfer Check Digit: Default is check digit and transmits.
- Add-on 2 or 5: Default is Off. When enable, add 2 or 5 digits at the end of all all decoded data.

## 2.4.6. ITF, STF, Matrix 2of5, IATA 2of5, Chinese Post Setup

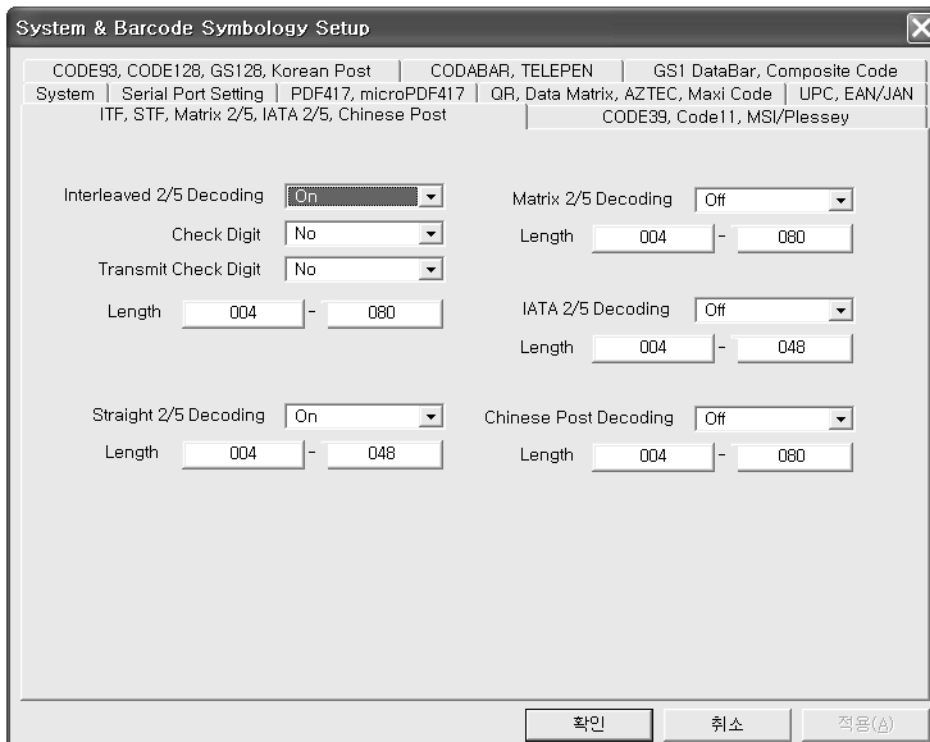

### Interleaved 2of5

- ITF Decoding: Default is On.
- Check Digit: Default is no check digit.
- Transfer Check Digit: Default is no transmits check digit.
- Data Length: Minimum Default = 4, Maximum Default is 80

Supported mode is as followings:

- No check digit, no transmitted check digit.
- Check digit, transmitted check digit.
- Check digit, no transmitted check digit.

### Straight 2of5 Industrial

- STF Decoding: Default is On.
- Data Length: Minimum Default = 4, Maximum Default is 48

### Matrix 2of5

- Matrix 2of5 Decoding: Default is Off.
- Data Length: Minimum Default = 4, Maximum Default is 80

The code is self-checking and does not include a checksum.

### IATA 2of5

- IATA 2of5 Decoding: Default is Off.
- Data Length: Minimum Default = 4, Maximum Default is 48

Used for baggage handling in the air-transport industry by the International Air Transport Agency.

### Chinese Post

- Chinese Post Decoding: Default is Off.
- Data Length: Minimum Default = 4, Maximum Default is 80

The China Postal Code is a variant on Matrix 2 of 5 but with modified start and stop characters.

## 2.4.7. Code39, Code11, MSI Setup

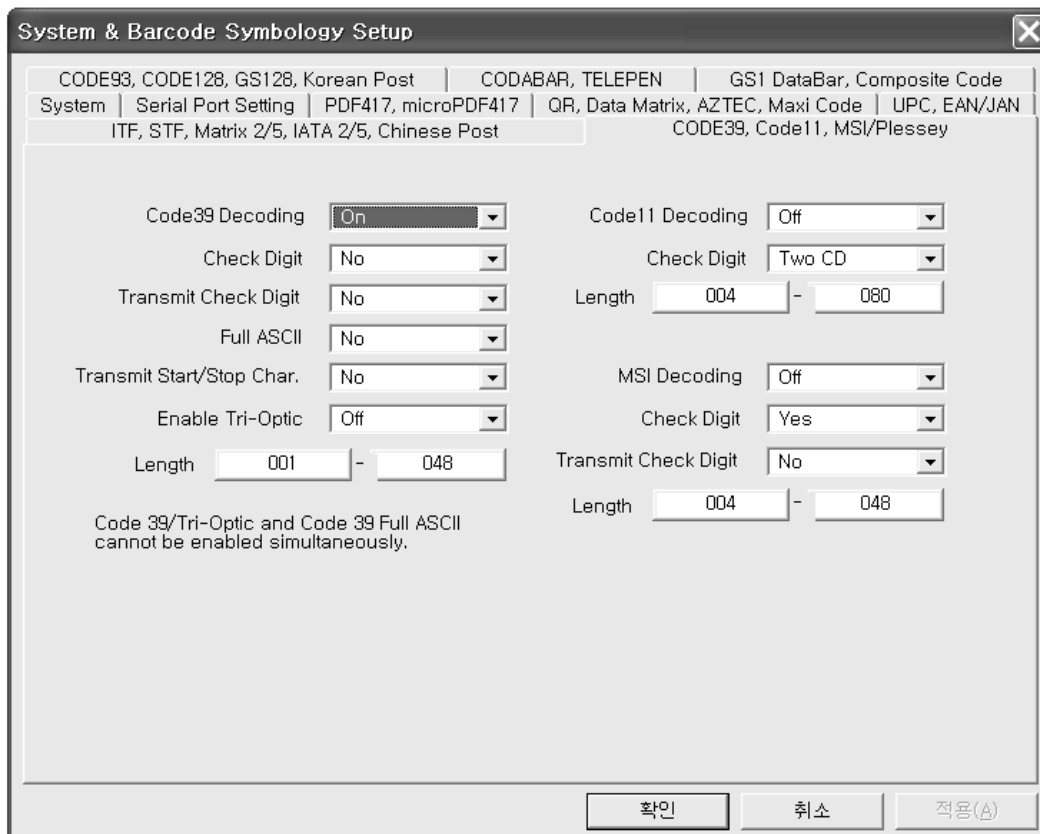

### Code39

- Enable/Disable Code39 Decoding, Check Digit, Transfer Check Digit, Full ASCII, Transfer Start/Stop character. Supported mode is as followings:
  - No check digit, no transmitted check digit, no full ASCII.
  - Check digit, transmitted check digit, no full ASCII.
  - Check digit, no transmitted check digit, no full ASCII.
  - No check digit, No transmitted check digit, full ASCII.
  - Check digit, transmitted check digit, full ASCII.
  - Check digit, no transmitted check digit, full ASCII.
- Enable Tri-Optic                      Default is Off.
- Data Length:                         Minimum Default = 1, Maximum Default is 48.

Code39/Tri-Optic and Code39 Full ASCII cannot be enabled simultaneously.

### Code11

- Code11 Decoding:                    Default is Off.
- Check Digit:                         Sets 1 or 2 check digits. Default is two check digits.
- Data Length:                         Minimum Default = 4, Maximum Default is 80.

### MSI / Plessey

- MSI Decoding:                        Default is Off.
- Check Digit:                         Default is check digit.
- Transfer Check Digit:                Support to No / CD1 / CD1+CD2. Default is no transmits check digit.
- Data Length:                         Minimum Default = 4, Maximum Default is 48

The checksum is calculated as the sum modulo 10 or 11 of the data characters. The checksum CD2 is calculated as the sum modulo 10 or 11 data the data characters and CD1.



## 2.4.8. Code93, Code128, GS128, Korean Post Setup

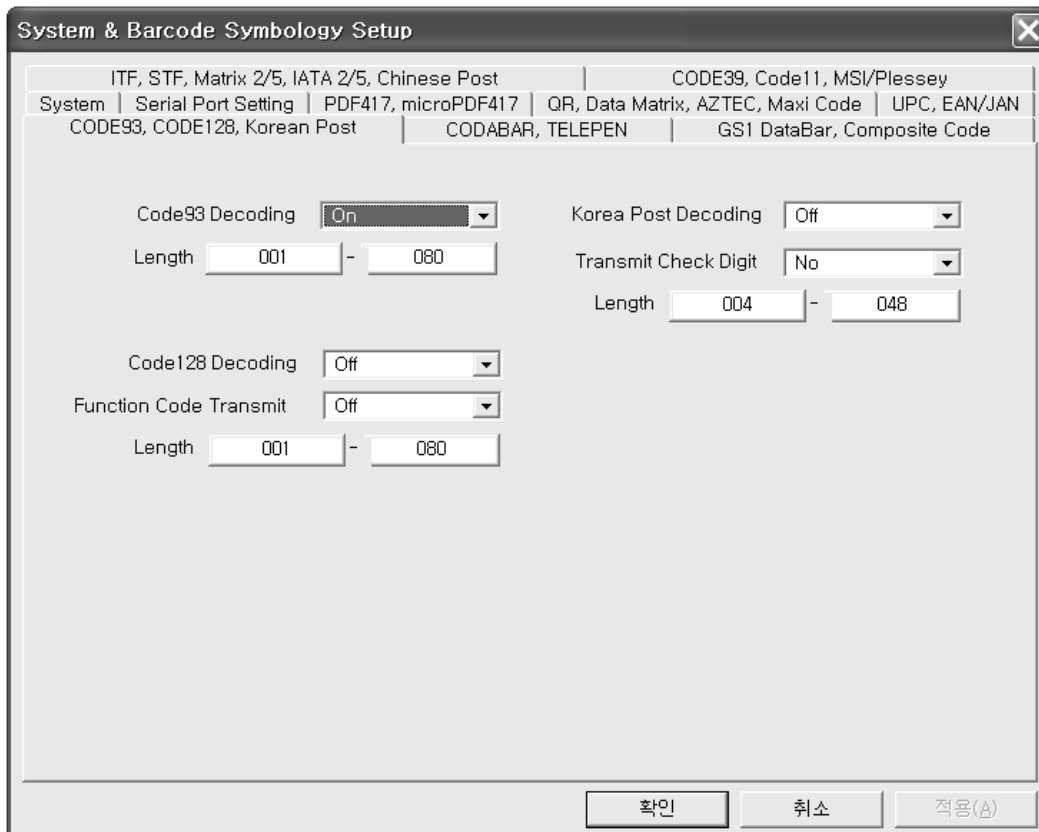

### Code93

- Code93 Decoding: Default is On.
- Data Length: Minimum Default = 1, Maximum Default is 80

### Code128

- Code128 Decoding: Default is On.
- FCN Code Transmit: Default is no transmitted Function Code.
- Data Length: Minimum Default = 4, Maximum Default is 80

### GS1-128

- GS1-128 Decoding: Default is On.
- Data Length: Minimum Default = 1, Maximum Default is 80

The GS1-128 Symbology is a subset of the more general Code 128 Symbology. By agreement between AIM, Inc and GS1, use of the Function Code 1 (FNC1) in Code 128 Symbols in the first symbol character position following the Start Character has been reserved exclusively for the GS1 System.

### Korean Post

- Korean Post Decoding: Default is Off.
- Transfer Check Digit: Default is no transmits check digit.
- Data Length: Minimum Default = 4, Maximum Default is 48

## 2.4.9. Codabar, Telepen Setup

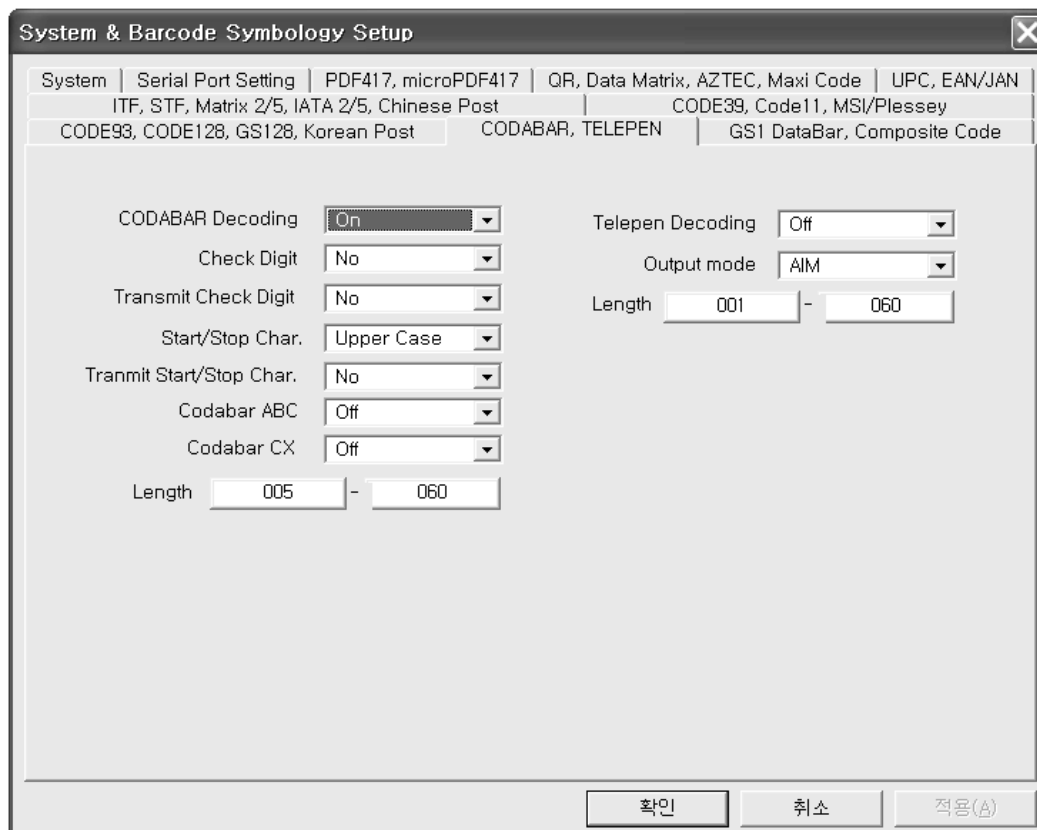

### Codabar

- Codabar Decoding: Default is On. Codabar is called NW-7 in Japan.
- Other Options: Enable or Disable Check Digit, Transfer Check Digit, Start/Stop character, Transfer Start/Stop character.
- Codabar ABC: Default is Off. Codabar ABC is special Codabar version. This code consists of two bar codes which are decoded in one read cycle, first and last character must be A,B or C.
- Codabar CX: Default is Off. This code consists of two bar codes which are decoded in one read cycle.
- Data Length: Minimum Default = 5, Maximum Default is 60

### Telepen

- Telepen Decoding: Default is Off.
- Output mode: AIM or Original. Default is AIM output mode.
- Data Length: Minimum Default = 1, Maximum Default is 60

Using AIM Output, the scanner reads symbols with start/stop pattern 1 and decodes to full ASCII (start/stop pattern 1).

When Original Telepen Output is selected, the scanner reads symbols with start/stop pattern 1 and decodes them as compressed numeric with optional full ASCII (start/stop pattern 2).

## 2.4.10. GS1 DataBar, Composite Code Setup

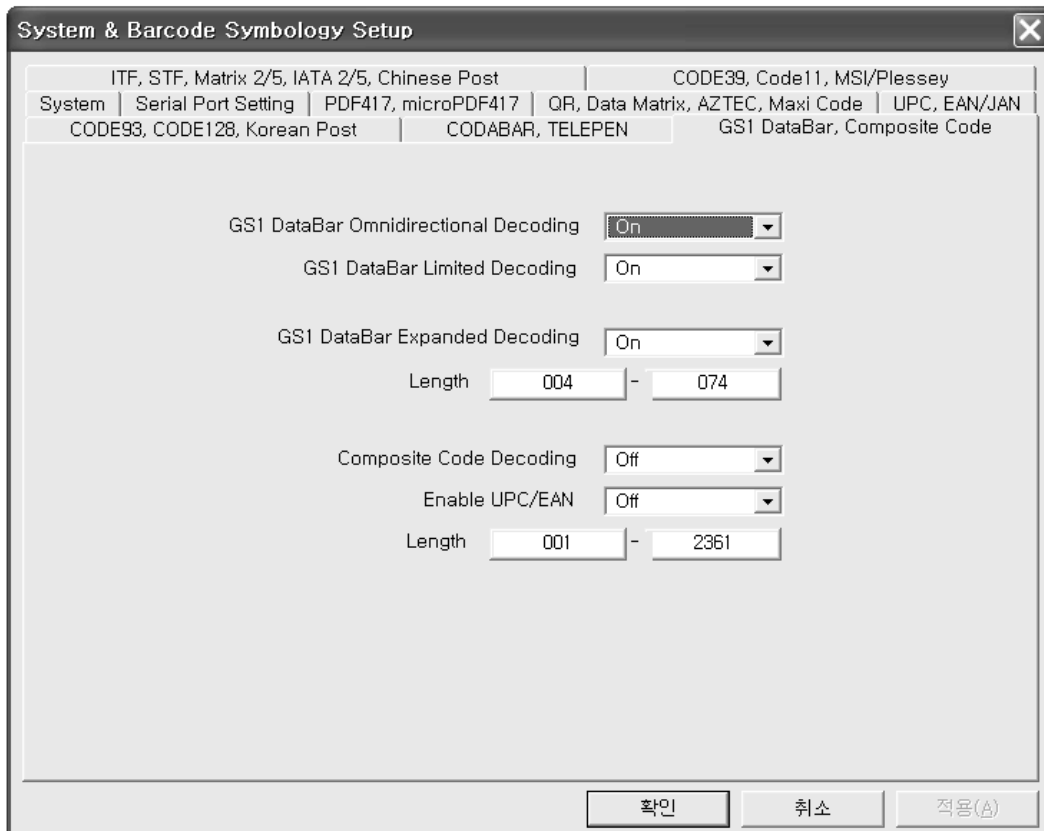

### GS1 DataBar

- GS1 DataBar Decoding Default is On. .

### GS1 DataBar Limited

- GS1 DataBar Limited Decoding Default is On. .

### GS1 DataBar Expanded

- GS1 DataBar Expanded decoding. Default is On.
- Data Length: Minimum Default = 4, Maximum Default is 74

Similar as EAN-128 but with reduced size

### Composite Code Decoding

- Composite Code Decoding. Default is Off.
- Enable UPC/EAN. Default OFF.
- Data Length: Minimum Default = 1, Maximum Default is 2361

### 3. Camera Setup

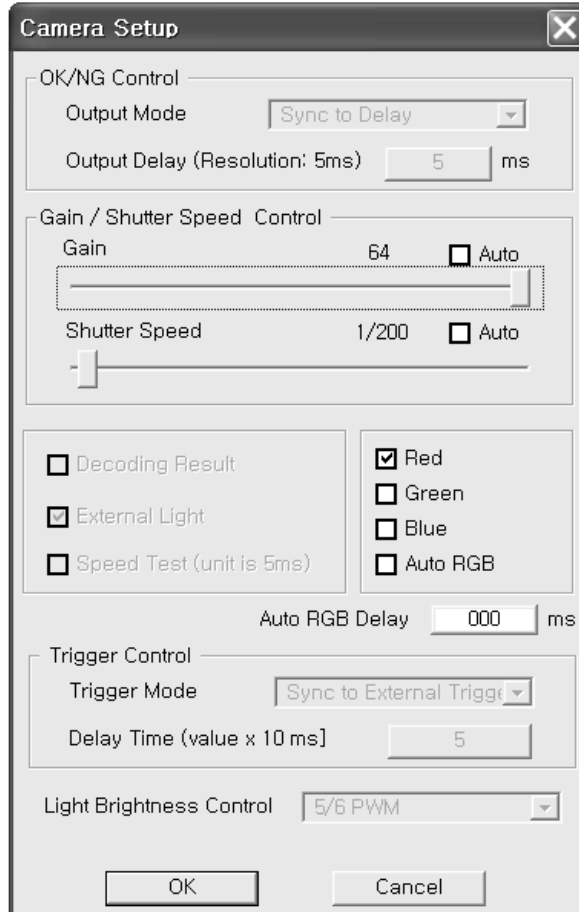

#### Gain Control

CMOS Sensor gain control.

- Auto Mode: Auto Gain control.
- Manual Mode: Can be adjusted to 16 ~ 64

#### Shutter Speed Control

CMOS Sensor shutter speed control.

- Auto Mode : Auto shutter speed control.
- Manual Mode: Can be adjusted to 1/30 ~ 1/10,000 sec

#### Decoding Result

Decoding result sent to the Host or not.

#### Red/Green/Blue

Specify the color of the LED Light. All selection is white lighting. Color can be selected depending on the target object. Default is Red LED operation for CSE-6100.

#### Auto RGB

Select a color is performed sequentially.

#### Auto RGB Delay

Sets an Auto RGB delay time.

## 4. Application Interface

This function is to support for software keyboard wedge emulation. Decoded data are delivered with target application program.

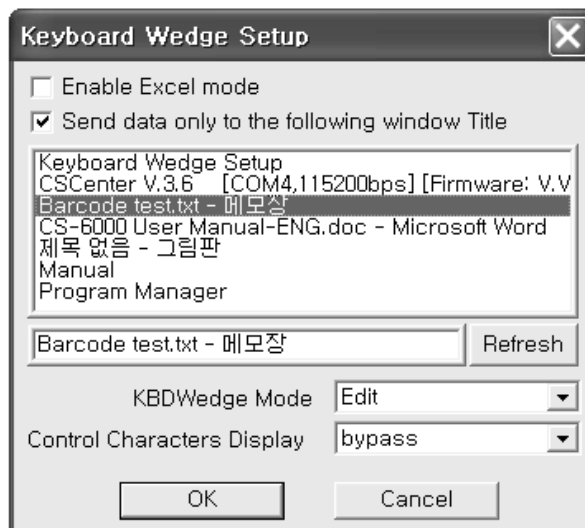

### Enable Excel Mode

It is generally recommended to use Keystroke mode, when using Excel program.

- Keystroke mode doesn't support Chinese characters and special symbols or marks.
- In case of displaying all characters including Chinese characters and special letters on Excel, please set Character mode to Edit and "Excel mode check box" to enable.

When no use of Excel program, please set this check box to disabled.

### Send data only to the following window Title

- Enables and disables Windows List Box.
- Default setting is available. Decoding data from scanner is sent to user application.

Selected application program must be able to support the clipboard or keyboard input.

### KBDWedge Mode

- Edit Mode.  
Default setting. All kinds of characters to be written can be displayed on application program.
- Keystroke Mode  
Play same role as inputting data via keyboard into application program.  
Except Chinese characters and special symbols or marks, numbers, English letters, Hiragana, Katakana and relative half width & full width characters can be displayed.

### Control Characters

Ignores or bypasses control characters input. Bypass mode is default setting.

## 5. Firmware Update

Firmware update of CSE-6100™ can be used by following 2 ways :

- ROM Update : Normal update mode.
- ROM Down : Urgent update mode.

**★ This function is not for general users but for general users, please do not use this function.**

### ROM Update (Normal update mode)

If you want to upgrade the scanner's firmware, you can load a new firmware file onto the scanner's ROM by following the processes:

1. Baud rate used as a 115,200 bps, 8 bits, No Parity, 1 Stop bit.
2. Click the "ROM Update" Button, then displayed 'Developer ID check' dialogue box. Enter your ID number , then displayed confirm dialogue box..

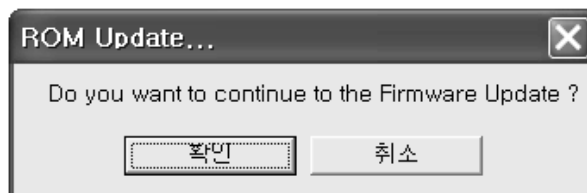
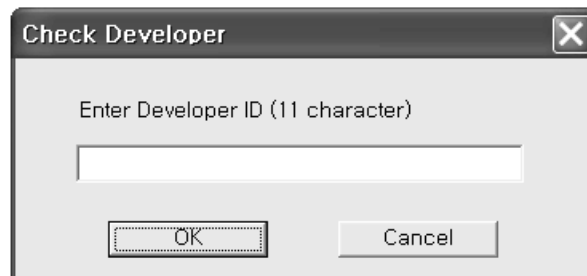

If have not ID number, Please contact the nearest technical support office.

3. Click "OK" button, then the File Selection Menu is displayed and display "[[[[Waiting Program Download]]]" message on text window.
4. Click the "ROM Down" Button, then displayed File Selection dialogue box. Select the target bin file and click on Open. Click "OK" button, CSCenter™ transfer bin file to scanner.

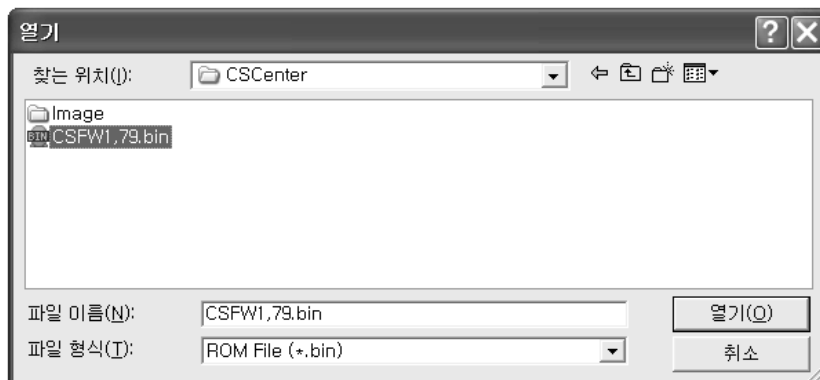

5. CSE-6100™ will flash the new software onto scanner's ROM. This status message is displayed on text window.

Firmware upgrade is processed like following:

- ① Firmware downloading start...
- ② Firmware downloading end !
- ③ Check Sum.
- ④ Download O.K.
- ⑤ Sector Erase is started.
- ⑥ Start of the data writing.
- ⑦ End of the data writing!!!
- ⑧ Verifying Start.
- ⑨ Verifying End!!!.
- ⑩ Restart the Scanner.

6. If firmware update fails or display the “No Application Image!” then use to “ROM Down” function.

#### **ROM Down (Urgent update mode)**

“Firmware Upgrade” may fail in the course of upgrade processes, due to its user make mistakes including accidentally powering off and etc. And then, the firmware upgrade should be redone by the below steps;

1. Power-off the CSE-6100™
2. Run the CSCenter.exe
3. Power-on the CSE-6100™, then “[[[Waiting Program Download]]]” message appears on Text Window.
4. Click the “ROM Down” Button, then displayed File Selection dialogue box. Select the target bin file and click on Open. Click “OK” button, CSCenter™ transfer bin file to scanner.
5. CSE-6100™ will flash the new software onto scanner’s ROM. This status message is displayed on text window.

## 6. Command summary

(\*) is default setting

Item	Setting	Command	
<b>COMMUNICATION</b>			
Frame Setting	COMM=Baudrate,Data bits,Parity,Stop bit,Flow[CR]		
	Baud rate	1,200 bps	1200
		2,400 bps	2400
		4,800 bps	4800
		9,600 bps	9600
		19,200 bps	19200
		38,400 bps	38400
		57,600 bps	57600
		115,200 bps(*)	115200
		460,800 bps for USB	460800
		614,400 bps for USB	614400
	Data Bits	5 bits	5
		6 bits	6
		7 bits	7
		8 bits (*)	8
	Parity	No Parity (*)	0
		Odd Parity	1
		Even Parity	2
	Stop Bit	1 Stop Bit (*)	1
		2 Stop Bit	2
Flow Control	None (*)	0	
	XON/XOFF Control	1	
	RTS/CTS Control	2	
Baud rate setting	1,200 bps	BAUDRATE=1200[CR]	
	2,400 bps	BAUDRATE=2400[CR]	
	4,800 bps	BAUDRATE=4800[CR]	
	9,600 bps	BAUDRATE=9600[CR]	
	19,200 bps	BAUDRATE=19200[CR]	
	38,400 bps	BAUDRATE=38400[CR]	
	57,600 bps	BAUDRATE=57600[CR]	
	115,200 bps(*)	BAUDRATE=115200[CR]	
	460,800 bps for USB	BAUDRATE=460800[CR]	
	614,400 bps for USB	BAUDRATE=614400[CR]	
Data Bits setting	5 bits	DATABIT=5[CR]	
	6 bits	DATABIT=6[CR]	
	7 bits	DATABIT=7[CR]	
	8 bits (*)	DATABIT=8[CR]	
Parity setting	No Parity (*)	PARITY=0[CR]	
	Odd Parity	PARITY=1[CR]	
	Even Parity	PARITY=2[CR]	
Stop Bit setting	1 Stop Bit (*)	STOPBIT=1[CR]	
	2 Stop Bit	STOPBIT=2[CR]	
Flow Control setting	None (*)	HANDSHAKE=0[CR]	
	XON/XOFF Control	HANDSHAKE=1[CR]	
	RTS/CTS Control	HANDSHAKE=2[CR]	



SYSTEM		
Header	None (*)	HEADER=0[CR]
	[STX]	HEADER=1[CR]
	[ESC]	HEADER=2[CR]
Terminators	None	TERMINATER=0[CR]
	[ETX]	TERMINATER=1[CR]
	[ETX] [CR]	TERMINATER=2[CR]
	[CR][LF] (*)	TERMINATER=3[CR]
	[CR]	TERMINATER=4[CR]
	[CR][TAB]	TERMINATER=5[CR]
	[TAB][CR]	TERMINATER=6[CR]
Transmit Code ID	None (*)	CODEID=0[CR]
	Simple	CODEID=1[CR]
	AIM	CODEID=2[CR]
Flashing LED	Flashing is off	FLASHING=0[CR]
	Flashing is on (*)	FLASHING=1[CR]
	Auto flashing	FLASHING=2[CR]
	On/Off flashing	FLASHING=3[CR]
Aiming On/Off	Aiming is off	AIMING=0[CR]
	Aiming is on (*)	AIMING=1[CR]
Ignore Same Result	Ignore same text is off (*)	SAMETEXT=0[CR]
	Ignore same text is on	SAMETEXT=1[CR]
Decode Size	720H * 480V	DECODESIZE=0[CR]
	640H * 480V (*)	DECODESIZE=1[CR]
Image Upload	Capture image auto-upload is off (*)	AUTOUPLOAD=0[CR]
	Upload image if OK	AUTOUPLOAD=1[CR]
	Upload image if NG	AUTOUPLOAD=2[CR]
Power Saving Control	Power saving is off	POWERSAVING=0[CR]
	Power saving is on (*)	POWERSAVING=1[CR]
Power-On Beep	Disable(*)	POWERONBEEP=0[CR]
	Enable	POWERONBEEP=1[CR]
Beep on Decoding	Off	DECODEBEEP=0[CR]
	On	DECODEBEEP=1[CR]
	On(NG)	DECODEBEEP=2[CR]
	On(Good) (*)	DECODEBEEP=3[CR]
Beep Volume	Off	BEEPVOLUME=0[CR]
	Low	BEEPVOLUME=1[CR]
	Medium (*)	BEEPVOLUME=2[CR]
	High	BEEPVOLUME=3[CR]
Capture & Decoding	Image Capture & Decoding	?CAP=1[CR]
Set Decoding count	For Capture & Decoding command	DECORDCNT=value[CR] Value is 1~999
Upload image	Capture Image upload to JPG file.	?IMG=1[CR]
Read Version Number	Request Scanner's Firmware Version	?VER=[CR]
Read Scanner's configuration	Request Scanner's Setting	?CFG=[CR]
Write all Parameter	Save parameters to Scanner's FROM.	?SAV=[CR]
Scan Mode	Normal (*)	SCANMODE=0[CR]
	Auto Capture	SCANMODE=1[CR]
	Continuous Capture	SCANMODE=2[CR]
Scan Time	Continuous Scan Time	SCANTIME=value[CR]
Scan Sense	Object detect sensitivity level setting for Auto-Capture mode	SCANSENSE=value[CR] Value is 0~9 (default is 1)
Factory default set	Factory default setting	FACTCFG=[CR]

<b>PDF-417</b>		
PDF417 Decoding	Off	PDF417=0[CR]
	On (*)	PDF417=1[CR]
Digit Length	Digit length mini/max. xxxx : Low, default 1 yyyy : High, default. 2710	PDF417LENGTH=xxxx,yyyy[CR]
<b>microPDF417</b>		
microPDF417 Decoding	Off (*)	MPDF417=0[CR]
	On	MPDF417=1[CR]
Digit Length	Digit length mini/max. xxxx : Low, default 1 yyyy : High, default. 366	MPDF417LENGTH=xxxx,yyyy[CR]
<b>DATAMATRIX</b>		
DATAMATRIX Decoding	Off	DATAMATRIX=0[CR]
	On & FCN enable (*)	DATAMATRIX=1[CR]
	On & FCN disable	DATAMATRIX=2[CR]
Digit Length	Digit length mini/max. xxxx : Low, default 1 yyyy : High, default. 3116	DMAXLENGTH =xxxx,yyyy[CR]
<b>QR</b>		
QR Decoding	Off	QR=0[CR]
	On (*)	QR=1[CR]
Digit Length	Digit length mini/max. xxxx : Low, default 1 yyyy : High, default. 7089	QRLENGTH=xxxx,yyyy[CR]
<b>AZTEC</b>		
AZTEC Decoding	Off (*)	AZTEC=0[CR]
	On	AZTEC =1[CR]
Digit Length	Digit length mini/max. xxxx : Low, default 1 yyyy : High, default. 3832	AZTECLENGTH=xxxx,yyyy[CR]
<b>MAXI code</b>		
MAXI Decoding	Off (*)	MAXI=0[CR]
	On	MAXI =1[CR]
Digit Length	Digit length mini/max. xxxx : Low, default 1 yyyy : High, default. 138	MAXILENGTH=xxxx,yyyy[CR]
<b>CODABAR</b>		
CODABAR Decoding	Decoding Off	CODABAR=0[CR]
	Decoding On, C/D Check Off(*)	CODABAR=1[CR]
	Decoding On, C/D check and transfer	CODABAR=2[CR]
	Decoding On C/D check and C/D no transfer	CODABAR=3[CR]
Start/Stop character	S/S character is lower case	CODABARSSKIND=0[CR]
	S/S character is higher case	CODABARSSKIND=1[CR]
Transmit Start/Stop character	Off	CODABARSSTX=0[CR]
	On	CODABARSSTX=1[CR]
Digit Length	Digit length mini/max. xxxx : Low, default 5 yyyy : High, default. 60	CBARLENGTH=xxxx,yyyy[CR]
Codabar ABC	Decoding off (*)	CBARABC=0[CR]
	Decoding on	CBARABC=1[CR]
Codabar CX	Decoding off (*)	CBARCX=0[CR]
	Decoding on	CBARCX=0[CR]

<b>TELEPEN</b>		
Telepen Decoding	Decoding Off (*)	TELEPEN=0[CR]
	Decoding On	TELEPEN=1[CR]
Output mode	AIM (*)	TELEPENMODE=0[CR]
	Original	TELEPENMODE=1[CR]
Digit Length	Digit length mini/max. xxxx : Low, default 1 yyyy : High, default. 60	TELEPENLENGTH=xxxx,yyyy[CR]
<b>CODE128</b>		
CODE128 Decoding	Off	CODE128=0[CR]
	On (*)	CODE128=1[CR]
C128FCN	Function Code Transmit is Off (*)	C128FCN=0[CR]
	Function Code Transmit is On	C128FCN=1[CR]
Digit Length	Digit length mini/max. xxxx : Low, default 1 yyyy : High, default. 80	C128LENGTH=xxxx,yyyy[CR]
<b>GS128</b>		
GS128 Decoding	Off (*)	GS128=0[CR]
	On	GS128=1[CR]
Digit Length	Digit length mini/max. xxxx : Low, default 1 yyyy : High, default. 80	GS128LENGTH=xxxx,yyyy[CR]
<b>KOREAN POST</b>		
Korean Post Decoding	Off (*)	KPOST=0[CR]
	On	KPOST=1[CR]
Transmit Check Digit	Off (*)	KPOSTCDTX=0[CR]
	On	KPOSTCDTX=1[CR]
Digit Length	Digit length mini/max. xxxx : Low, default 4 yyyy : High, default. 48	KPOSTLENGTH=xxxx,yyyy[CR]
<b>CODE93</b>		
CODE93 Decoding	Off	CODE93=0[CR]
	On (*)	CODE93=1[CR]
Digit Length	Digit length mini/max. xxxx : Low, default 1 yyyy : High, default. 80	C93LENGTH=xxxx,yyyy[CR]
<b>CODE39</b>		
CODE39 Decoding	Decoding Off	CODE39=0[CR]
	Decoding On, C/D Check Off (*)	CODE39=1[CR]
	Decoding On, C/D check and C/D transfer	CODE39=2[CR]
	Decoding On C/D check and C/D no transfer	CODE39=3[CR]
	Decoding On, CD Check Off, Full ASCII On	CODE39=4[CR]
	Decoding On, CD Check On, C/D Transfer, Full ASCII On	CODE39=5[CR]
	Decoding On, CD Check On, Not C/D Transfer, Full ASCII On	CODE39=6[CR]
Transmit Start/Stop character	Off (*)	CODE39SSTX=0[CR]
	On	CODE39SSTX=1[CR]
Digit Length	Digit length mini/max. xxxx : Low, default 1 yyyy : High, default. 48	C39LENGTH=xxxx,yyyy[CR]
Tri-Optic Decoding	Decoding Off (*)	TRIOPTIC=0[CR]
	Decoding On	TRIOPTIC=1[CR]

<b>CODE11</b>		
Code11 Decoding	Decoding Off (*)	CODE11=0[CR]
	Decoding On	CODE11=1[CR]
Check Digit	One Check Digit	CODE11CDCHK=0[CR]
	Two Check Digit (*)	CODE11CDCHK=1[CR]
Digit Length	Digit length mini/max. xxxx : Low, default 4 yyyy : High, default. 80	C11LENGTH=xxxx,yyyy[CR]
<b>MSI / Plessey</b>		
MSI/Plessey Decoding	Decoding Off (*)	MSI=0[CR]
	Decoding On	MSI=1[CR]
Check Digit	Off	MSICDCHK=0[CR]
	On (*)	MSICDCHK=1[CR]
Transfer Check Digit	No (*)	MSICDTX=0[CR]
	CD1	MSICDTX=1[CR]
	CD1 + CD2	MSICDTX=2[CR]
Digit Length	Digit length mini/max. xxxx : Low, default 4 yyyy : High, default. 80	MSILENGTH=xxxx,yyyy[CR]
<b>Interleaved 2 of 5</b>		
ITF Decoding	Decoding Off	ITF=0[CR]
	Decoding On, not CD check (*)	ITF=1[CR]
	Decoding On, CD Check, CD transfer	ITF=2[CR]
	Decoding On, CD Check, no CD transfer	ITF=3[CR]
Digit Length	Digit length mini/max. xxxx : Low, default 4 yyyy : High, default. 80	ITFLENGTH=xxxx,yyyy[CR]
<b>Straight 2 of 5</b>		
STF Decoding	Decoding Off	STF=0[CR]
	Decoding On (*)	STF=1[CR]
Digit Length	Digit length mini/max. xxxx : Low, default 4 yyyy : High, default. 48	STFLENGTH=xxxx,yyyy[CR]
<b>MATRIX 2 of 5</b>		
Matrix25 Decoding	Decoding Off (*)	MATRIX25=0[CR]
	Decoding On	MATRIX25=1[CR]
Digit Length	Digit length mini/max. xxxx : Low, default 4 yyyy : High, default. 80	MATRIX25LENGTH=xxxx,yyyy[CR]
<b>IATA 2 of 5</b>		
IATA Decoding	Decoding Off (*)	IATA=0[CR]
	Decoding On	IATA=1[CR]
Digit Length	Digit length mini/max. xxxx : Low, default 4 yyyy : High, default. 48	IATALENGTH=xxxx,yyyy[CR]
<b>Chinese Post</b>		
Chinese Post Decoding	Decoding Off (*)	CPOST=0[CR]
	Decoding On	CPOST=1[CR]
Digit Length	Digit length mini/max. xxxx : Low, default 4 yyyy : High, default. 80	CPOSTLENGTH=xxxx,yyyy[CR]

<b>UPC</b>		
UPC-A Decoding	Off	UPC=0[CR]
	On (*)	UPC=1[CR]
UPC-A Length	12 Digit	UPCLENGTH=0[CR]
	13 Digit (*)	UPCLENGTH=1[CR]
UPC-A Add-on	Off (*)	UPCADDON=0[CR]
	2 Digit	UPCADDON=1[CR]
	5 Digit	UPCADDON=2[CR]
UPC-E0 Decoding	Off	UPCE=0[CR]
	On (*)	UPCE=1[CR]
UPC-E1 Decoding	Off (*)	UPCE1=0[CR]
	On	UPCE1=1[CR]
UPC-E0 Expand	Off (*)	UPCEEXP=0[CR]
	On	UPCEEXP=1[CR]
UPC-E Length	12 Digit	UPCECDTX=0[CR]
	13 Digit (*)	UPCECDTX=1[CR]
UPC-E Add-on	Off (*)	UPCEADDON=0[CR]
	2 Digit	UPCEADDON=1[CR]
	5 Digit	UPCEADDON=2[CR]
<b>EAN/JAN-13</b>		
EAN13 Decoding	Decoding Off	EAN13=0[CR]
	Decoding On (*)	EAN13=1[CR]
EAN13 Length	12 Digit	EAN13CDTX=0[CR]
	13 Digit (*)	EAN13CDTX=1[CR]
Add-on 2 or 5	Off (*)	EAN13ADDON=0[CR]
	2 Digit	EAN13ADDON=1[CR]
	5 Digit	EAN13ADDON=2[CR]
<b>EAN/JAN-8</b>		
EAN8 Decoding	Decoding Off	EAN8=0[CR]
	Decoding On (*)	EAN8=1[CR]
EAN8 Length	12 Digit	EAN8CDTX=0[CR]
	13 Digit (*)	EAN8CDTX=1[CR]
Add-on 2 or 5	Off (*)	EAN8ADDON=0[CR]
	2 Digit	EAN8ADDON=1[CR]
	5 Digit	EAN8ADDON=2[CR]
<b>DataBar</b>		
RSS14 Decoding	Off (*)	RSS14=0[CR]
	On	RSS14=1[CR]
RSS Limited Decoding	Off (*)	RSSL=0[CR]
	On	RSSL=1[CR]
RSSEXP Decoding	Off (*)	RSSEXP=0[CR]
	On	RSSEXP=1[CR]
RSSEXPLENGTH	Digit length mini/max. xxxx : Low, default 4 yyyy : High, default. 74	RSSEXPLENGTH=xxxx,yyyy[CR]
<b>Composite Code</b>		
Composite Decoding	Off (*)	RSSCOMP=0[CR]
	On	RSSCOMP=1[CR]
Enable UPC/EAN	Off (*)	RSSCOMPEAN=0[CR]
	On	RSSCOMPEAN=1[CR]
RSSEXPLENGTH	Digit length mini/max. xxxx : Low, default 1 yyyy : High, default. 2361	RSSCOMPLENGTH=xxxx,yyyy[CR]

CAMERA		
Auto-Gain control	Disable (*)	AGAIN=0[CR]
	Enable	AGAIN=1[CR]
Auto-Shutter control	Disable (*)	ASHUTTER=0[CR]
	Enable	ASHUTTER=1[CR]
Manual Gain Value	Gain Value	GAINVAL=[Value][CR]
Manual Shutter Speed	Shutter Speed Value	SHTSPD=[Value][CR]

- ✦ High engineering knowledge is requested for these items, standard setting is recommended for normal users.
- ✦ The standard setting could be the best selection in most ordinary working environment.
- ✦ Also these items are controlled by firmware itself and can be used for special purpose.

SETUP		
Setup start	Setup start	?SETUPSTART=[CR]
Setup Exit	Setup Exit	?SETUPCANCEL=[CR]
Save & Exit	Saved parameters and exit setup	?SETUPEXIT=[CR]

RGB LED		
Red LED	Off	XRED=0[CR]
	On (*)	XRED=1[CR]
Green LED	Off (*)	XGREEN=0[CR]
	On	XGREEN=1[CR]
Blue LED	Off (*)	XBLUE=0[CR]
	On	XBLUE=1[CR]
RGB LED auto-Flashing	Off (*)	XAUTORGB=0[CR]
	On	XAUTORGB=1[CR]

## 7. Configuring using barcodes

### 7.1. Start, Save & Exit

Setup Start



Default



Save & Exit



Setup Cancel



### 7.2. Communications

#### Baud rate setting

Baud Rate Setting controls the speed at which a message string is transmitted via RS-232 between The CSE-6100 and a host computer. The higher the baud rate, the faster the transmission.

1,200bps



2,400bps



4,800bps



9,600bps



19,200bps



38,400bps



57,600bps



115,200bps (Default)



460,800bps



614,400bps



### Data Bits

Data Bits set character format for the number of data bits to 5, 6, 7, 8 bits.

5 Bits



6 Bits



7 Bits



8 Bits (Default)



### Parity Bits

Parity Bits enable the selection of parity bits for character validation. If the CSE-6100 has already been programmed for 8 data bits, then "No Parity" can be selected. However, when using 7 data bits, any of the three parity choices may be selected.

No Parity (Default)



Odd Parity



Even Parity





## Stop Bits

Stop Bits provide the option of using either 1 or 2 bits as stop bits at the end of a character format.

1 Stop Bit (Default)



2 Stop Bit



## Flow Control

Flow control is data acknowledgment protocol.

None (Default)



XON/XOFF



RTS/CTS



### 7.3. System

#### Header

Set communication header to None, STX, ESC

None (Default)



STX



ESC



#### Terminator

Set communication terminator to [ETX], [ETX][CR], [CR][LF], [CR], [CR][TAB], [TAB][CR]

None



ETX



ETX+CR



CR+LF (Default)



CR



CR+TAB



TAB+CR



### Transmit Code ID

A Code ID of a decoded barcode. Code ID character is inserted between the prefix and the decoded data.

No Transmit(Default)



Simple



AIM



### Flashing LED

Off



ON (Default)



AUTO



On/Off



### Aiming Control

Off



ON (Default)



**Ignore same decoding result**

Off (default)



On



**Resolution (Select Decoding Size)**

640H\*480V (default)



720H\*480V



**Auto Upload**

Disable (Default)



Upload if OK



Upload if NG



**Power Saving Mode**

Disable



Enable (Default)



### Power-On Beep

Disable (Default)



Enable (Default)



### Beep-On Decoding

Disable



Enable



Enable / NG



Enable (GOOD) (Default)



### Beep Volume

Off



Low



Medium



High



## LCD Comm.

Disable



Enable



Set the LCD communication service for Auto-Capture and Continuous Capture mode.

## 7.4. 2D barcode symbologies

### PDF417

This will enable or disable decoding of the PDF417 symbologies.

Disable



Enable (Default)



### microPDF417

This will enable or disable decoding of the microPDF417 Symbologies.

Disable (Default)



Enable



### DATA MATRIX

This will enable or disable decoding of the DataMatrix symbologies.

Disable



Enable & FCN character (Default)



Enable & Disable FCN character



## QR

This will enable or disable decoding of the QR symbologies.

Disable QR



Enable (Default)



## AZTEC

This will enable or disable decoding of the AZTEC Symbologies.

Disable (Default)



Enable



## MAXI Code

This will enable or disable decoding of the MAXI code Symbologies.

Disable (Default)



Enable





## 7.5. 1D barcode symbologies

### Coda bar

This will enable or disable decoding of the coda bar Symbologies.

Disable



Enable, C/D Check Off (Default)



Enable C/D Check, C/D transfer



Enable, C/D Check, C/D not transfer



Start/Stop character is lower case



Start/Stop character is upper case (Default)



Not transfer Start/Stop character (Default)



Transfer Start/Stop character



Disable Codabar ABC (Default)



Enable Codabar ABC



Disable Codabar CX (Default)



Enable Codabar CX



### Telepen

This will enable or disable decoding of the Telepen Symbolologies

Disable (Default)



Enable



Output mode is AIM (Default)



Output mode is original



### Code128

This will enable or disable decoding of the Code 128 Symbologies

Disable



Enable (Default)



Function Code Transmit is Off (Default)



Function Code Transmit is On



### GS128

This will enable or disable decoding of the GS128 Symbologies

Disable (Default)



Enable



### Code 93

This will enable or disable decoding of the Code 93 Symbologies

Disable



Enable (Default)



## Korean Post

This will enable or disable decoding of the Korean Post Symbologies

Disable (Default)



Enable



Disable Transfer Check Digit (Default)



Enable Transfer Check Digit



## Code 39

This will enable or disable decoding the non-full ASCII version of the Code 39 Symbologies.

Disable



Enable, C/D Check Off (Default)



Enable, C/D Check and C/D Transfer



Enable, C/D Check, C/D not transfer



Enable, C/D Check Off and Full ASCII



Enable, C/D Check, Transfer C/D and Full ASCII



Enable, C/D Check, not C/D Transfer and Full ASCII



### Code 39 Start/Stop Characters

The start/stop characters are represented by the asterisk (\*) character. By enabling this option, the data is preceded and appended with an asterisk. For example if the data is 1234, the CSE-6100 outputs the data as follows.

Disable: 1234  
 Enable: \*1234\*

Disable (Default)



Enable



### Tri-Optic

Disable (Default)



Enable



### Code11

This will enable or disable decoding of the Code11 Symbologies.

Disable (Default)



Enable



One Check Digit



Two Enable Check Digit (Default)



### MSI / Plessey

This will enable or disable decoding of the MSI / Plessey Symbologies.

Disable (Default)



Enable



Disable Check Digit



Enable Check Digit (Default)



Transfer Check Digit is Off (Default)



Transfer Check Digit is CD1



Transfer Check Digit is CD1+CD2



### Interleaved 2 of 5

This will enable or disable decoding of the Interleaved 2 of 5 Symbologies

Disable



Enable, C/D Check (Default)



Enable, C/D Check and C/D Transfer



Enable, C/D Check, not C/D transfer



### Straight 2 of 5

Disable



Enable (Default)



### Matrix 2 of 5

Disable (Default)



Enable



### IATA 2 of 5

Disable (Default)



Enable



### Chinese Post

Disable (Default)



Enable





## UPC

This will enable or disable decoding of the Universal Product Code (UPC) symbologies.

Disable UPC-A



Enable UPC-A (Default)



UPC-A Length is 12 digits



UPC-A Length is 12 digits



UPC-A add-on off (Default)



UPC-A add-on is 2 digits



UPC-A add-on is 5 digits



Disable UPC-E0



Enable UPC-E0 (Default)



Disable UPC-E1 (Default)



Enable UPC-E0



Disable UPC-E0 Expand (Default)



Enable UPC-E0 Expand



UPC-E Length is 12 digits



UPC-E Length is 13 digits (Default)



UPC-E add-on off (Default)



UPC-E add-on is 2 digits



UPC-E add-on is 5 digits



### EAN / JAN-13

Disable EAN-13



Enable EAN-13 (Default)



EAN-13 Length is 12 digits



EAN-13 Length is 13 digits (Default)



EAN-13 add-on off (Default)



EAN-13 add-on is 2 digits



EAN-13 add-on is 5 digits



## EAN / JAN-8

Disable EAN-8



Enable EAN-8 (Default)



EAN-8 Length is 12 digits



EAN-8 Length is 13 digits (Default)



EAN-8 add-on off (Default)



EAN-8 add-on is 2 digits



EAN-8 add-on is 5 digits



**DataBar**

Disable RSS14 (Default)



Enable RSS14



Disable RSS Limited (Default)



Enable RSS Limited



Disable RSS Expanded (Default)



Enable RSS Expanded



## 7.6. Composite Code

### Gain Control

Disable (Default)



Enable



Disable on UPC/EAN (Default)



Enable on UPC/EAN



## 7.7. LED control

### RGB LED control

Disable Red LED



Enable Red LED (Default)



Disable Green LED (Default)



Enable Green LED



Disable Blue LED (Default)



Enable Blue LED



### RGB LED flashing control

Disable auto-RGB flashing (Default)



Enable auto-RGB flashing



## 7.8. Scan mode (Direct Operation)

Set to Normal, Auto Capture and Continuous Capture mode.

**This mode is direct operation.**

Normal (Default)



Auto Capture



Continuous Capture





## 8. Data Transmission format

Data transmission format may be two different types upto its option.

In case that Code ID transmission option is disabled.

Header	Decoding Data	Terminator
--------	---------------	------------

(2) In case that Code ID Transmission option is enabled.

Code ID	Header	Decoding Data	Terminator
---------	--------	---------------	------------

- Code ID  
Code ID is provided for each Barcode Symbology, and you may choose one of three options below:

- None
- Simple Code ID
- AIM Code ID

☎ Please refer to the Code ID Table in the user manual for Code Value which is not transmitted.

- Header  
You may choose one of the options below.

- [None] (Default)
- [STX]
- [ESC]

- Terminator  
You may choose one of the options below:

- [None]
- [ETX]
- [ETX] + [CR]
- [CR] + [LF] (Default)
- [CR]
- [CR] + [TAB]
- [TAB] + [CR]

☎ Control Character is used for Header and Terminator, and please refer to the ASCII Code Table for Control Character.

**[Example 1] In case of Default setting**

- Code ID Transmission
- Header : [None]
- Terminator : [CR] + [LF]
- Decoding result: "1234567"

**Transmission Result: 1234567[CR][LF]**

☎ [CR] stands for 0x0d while [LF] stands for 0x0a.

**[Example 2] In case of Header/Terminator**

- Code ID Transmission
- Header : [ESC]
- Terminator : [ETX] + [CR]
- Decoding Result : "1234567"

**Transmission Result: [ESC]1234567[CR][TAB]**

☎ [ESC] stands for 0x1B while [ETX] stands for 0x03.

**[Example 3] In case of Code ID(Simple Code ID) Transmission**

- Code ID Transmission: Enable, Simple Code ID
- Header : [ESC]
- Terminator : [ETX] + [CR]
- Decoding Result: "1234567"
- Symbology: QR

**Transmission Result: Q[ESC]1234567[CR][TAB]**

☎ [ESC] stands for 0x1B, [CR] for 0x0d, and [ETX] stands for 0x03.

☎ **Q is a Simple Code ID of QR.**

**[Example 4] In case of Code ID Transmission(AIM Code ID)**

- Code ID (transmission): Enable, AIM Code ID
- Header : [ESC]
- Terminator : [ETX] + [CR]
- Decoding Result: "1234567"
- Symbology: QR

**Transmission Result: ]Qm[ESC]1234567[CR][TAB]**

☎ [ESC] Stands for 0x1B, [CR] for 0x0d, and [ETX] stands for 0x03.

☎ **QM is an AIM Code ID of QR.**

## 9. Code ID Table

Symbology	AIM ID	Simple
UPC-A	]E0	A
EAN-13	]E0	B
UPC-E	]E0	C
UPC-A with Add-On	]E3	D
UPC-E with Add-On	]E3	E
UPC-E1	]X0	F
EAN-13 with Add-On	]E3	G
EAN-8	]E4	H
EAN-8 with Add-On	]E3	I
CODE39	]Am	J
Tri-Optic	]X0	K
Codabar	]Fm	L
Codabar ABC	]Fm	M
Codabar CX	]X0	N
Straight 2 of 5 Industrial	]S0	O
Interleaved 2 of 5	]Im	P
Matrix 2 of 5	]X0	Q
Straight 2 of 5 IATA	]R0	R
China Post	]X0	S
MSI/Plessey	]Mm	T
Telepen	]Bm	U
Code 128	]Cm	V
GS1-128	]Cm	W
CODE93	]Gm	X
Code 11	]H3	Y
Korea Post	]X0	Z
GS1 DataBar	]e0	a
GS1 Composite	]em	b
PDF417	]Lm	d
MicroPDF417	]Lm	d
Data Matrix	]dm	e
Aztec Code	]zm	f
QR	]Qm	g
MaxiCode	]Um	h

AIM is a code ID mark system compliant with the AIM USA “Guidelines on Symbology Identifiers.” The “m” suffix differs depending upon the data transmission format of each barcode system. Refer to International Technical Specification, Symbology Identifiers, for AIM modifier character details.

## 10. ASCII conversion chart (Code Page 1252)

DEC	HEX	OCT	Char	DEC	HEX	OCT	Char	DEC	HEX	OCT	Char
0	00	000	Ctrl-@ NUL	43	2B	053	+	86	56	126	V
1	01	001	Ctrl-A SOH	44	2C	054	,	87	57	127	W
2	02	002	Ctrl-B STX	45	2D	055	-	88	58	130	X
3	03	003	Ctrl-C ETX	46	2E	056	.	89	59	131	Y
4	04	004	Ctrl-D EOT	47	2F	057	/	90	5A	132	Z
5	05	005	Ctrl-E ENQ	48	30	060	0	91	5B	133	[
6	06	006	Ctrl-F ACK	49	31	061	1	92	5C	134	\
7	07	007	Ctrl-G BEL	50	32	062	2	93	5D	135	]
8	08	010	Ctrl-H BS	51	33	063	3	94	5E	136	^
9	09	011	Ctrl-I HT	52	34	064	4	95	5F	137	_
10	0A	012	Ctrl-J LF	53	35	065	5	96	60	140	`
11	0B	013	Ctrl-K VT	54	36	066	6	97	61	141	a
12	0C	014	Ctrl-L FF	55	37	067	7	98	62	142	b
13	0D	015	Ctrl-M CR	56	38	070	8	99	63	143	c
14	0E	016	Ctrl-N SO	57	39	071	9	100	64	144	d
15	0F	017	Ctrl-O SI	58	3A	072	:	101	65	145	e
16	10	020	Ctrl-P DLE	59	3B	073	:	102	66	146	f
17	11	021	Ctrl-Q DC1	60	3C	074	<	103	67	147	g
18	12	022	Ctrl-R DC2	61	3D	075	=	104	68	150	h
19	13	023	Ctrl-S DC3	62	3E	076	>	105	69	151	i
20	14	024	Ctrl-T DC4	63	3F	077	?	106	6A	152	j
21	15	025	Ctrl-U NAK	64	40	100	@	107	6B	153	k
22	16	026	Ctrl-V SYN	65	41	101	A	108	6C	154	l
23	17	027	Ctrl-W ETB	66	42	102	B	109	6D	155	m
24	18	030	Ctrl-X CAN	67	43	103	C	110	6E	156	n
25	19	031	Ctrl-Y EM	68	44	104	D	111	6F	157	o
26	1A	032	Ctrl-Z SUB	69	45	105	E	112	70	160	p
27	1B	033	Ctrl-[ ESC	70	46	106	F	113	71	161	q
28	1C	034	Ctrl-\ FS	71	47	107	G	114	72	162	r
29	1D	035	Ctrl-] GS	72	48	110	H	115	73	163	s
30	1E	036	Ctrl-^ RS	73	49	111	I	116	74	164	t
31	1F	037	Ctrl_ US	74	4A	112	J	117	75	165	u
32	20	040	Space	75	4B	113	K	118	76	166	v
33	21	041	!	76	4C	114	L	119	77	167	w
34	22	042	*	77	4D	115	M	120	78	170	x
35	23	043	#	78	4E	116	N	121	79	171	y
36	24	044	\$	79	4F	117	O	122	7A	172	z
37	25	045	%	80	50	120	P	123	7B	173	{
38	26	046	&	81	51	121	Q	124	7C	174	
39	27	047	'	82	52	122	R	125	7D	175	}
40	28	050	(	83	53	123	S	126	7E	176	

## 11. Hex & ASCII table

### Hex table

	0	1	2	3	4	5	6	7	8	9	10	11	12	13	14	15
0	00	01	02	03	04	05	06	07	08	09	0A	0B	0C	0D	0E	0F
16	10	11	12	13	14	15	16	17	18	19	1A	1B	1C	1D	1E	1F
32	20	21	22	23	24	25	26	27	28	29	2A	2B	2C	2D	2E	2F
48	30	31	32	33	34	35	36	37	38	39	3A	3B	3C	3D	3E	3F
64	40	41	42	43	44	45	46	47	48	49	4A	4B	4C	4D	4E	4F
80	50	51	52	53	54	55	56	57	58	59	5A	5B	5C	5D	5E	5F
96	60	61	62	63	64	65	66	67	68	69	6A	6B	6C	6D	6E	6F
112	70	71	72	73	74	75	76	77	78	79	7A	7B	7C	7D	7E	7F
128	80	81	82	83	84	85	86	87	88	89	8A	8B	8C	8D	8E	8F
144	90	91	92	93	94	95	96	97	98	99	9A	9B	9C	9D	9E	9F
160	A0	A1	A2	A3	A4	A5	A6	A7	A8	A9	AA	AB	AC	AD	AE	AF
176	B0	B1	B2	B3	B4	B5	B6	B7	B8	B9	BA	BB	BC	BD	BE	BF
192	C0	C1	C2	C3	C4	C5	C6	C7	C8	C9	CA	CB	CC	CD	CE	CF
208	D0	D1	D2	D3	D4	D5	D6	D7	D8	D9	DA	DB	DC	DD	DE	DF
224	E0	E1	E2	E3	E4	E5	E6	E7	E8	E9	EA	EB	EC	ED	EE	EF
240	F0	F1	F2	F3	F4	F5	F6	F7	F8	F9	FA	FB	FC	FD	FE	FF

### ASCII table

	0	1	2	3	4	5	6	7	8	9	10	11	12	13	14	15
32	‘	!	“	#	\$	%	&	‘	(	)	*	+	,	-	.	/
48	0	1	2	3	4	5	6	7	8	9	:	;	<	=	>	?
64	@	A	B	C	D	E	F	G	H	I	J	K	L	M	N	O
80	P	Q	R	S	T	U	V	W	X	Y	Z	[	\	]	^	_
96	`	a	b	c	d	e	f	g	h	i	j	k	l	m	n	o
112	p	q	r	s	t	u	v	w	x	y	z	{		}	~	

## 12. CSE-6100™ Specification Sheet

Model	
CSE-6100S	Standard angle version
CSE-6100W	Wide angle version
Performance Characteristics	
Image Sensor	CMOS Sensor, max. 720H*480V, 8-bits Gray Scale.
Frame Rate	1/60 fps
Shutter Speed	1/30 sec ~ 1/10,000 sec
Viewing Angle	High density version: $\pm 53^\circ$ Standard density version: $\pm 40^\circ$
Ambient Lighting	Total darkness to full sunlight
Reverse, Flip Image	Auto-detection
Directions	360 ° Omni-directional
Interface	
Host Interface	RS232C-TTL interface
Control Signal	Trigger switch
Aiming	Smart laser aiming. 650nm $\pm$ 10nm
Indicator	Two Status LED output, Buzzer output
Symbologies	
1 Dimensional	UPC-A/E, EAN-8/13, Code39, Tri-Optic, Coda bar/ABC/CX, Straight 2 of 5 Industrial, Interleaved 2 of 5, Matrix 2 of 5, IATA, Chinese Post, Korean Post, MSI/Plessey, Code-93, Code128, GS1-128, Code11, GS1 DataBar
2 Dimensional	QR (with Chinese QR), Data Matrix, PDF417, microPDF417, Aztec, Maxi Code
Mechanical & Electrical	
Dimension	Height (12.4 mm), Width (20 mm), Depth (17.5 mm)
Weight	8g with cable
Cable Length	45 mm, FPC cable
Power Consumption	+4.75 to 5.25V, Typical 200mA, Peak 400mA, Standby 130mA
Environments & Regulatory	
Operating Temperature	-10°C to +50°C (-14°F to 122°F)
Operating Storage	-20°C to +60°C (-4°F to 140°F)
Humidity	0 to 95%
Certification	FCC Class A & CE, ROHS
Others	
Setup	Auto-configuration or using CSCenter™, Barcode, Command
Application Interface	Use CSCenter™
Hardware Control	Auto-detection, USB port Plug-In/Out is free

## 13. Maintenance

### 13.1. CSE-6100™ Attentive Points for Using

#### Cleaning

- Please do not clean CSE-6100 on your own.
- Lens is extremely important component for barcode reading.  
In case of cleaning the lens, please get rid of unnecessary external pressure and use soft towel for cleaning its surface.
- Do not use chemical detergent for cleaning its window or body.

#### Operating

- Do not give unnecessary external pressure or throw it. Many delicate & weak parts are included in its body.
- USB cable shall be plugged into the regularly same USB Port, otherwise driver setting must be redone.
- Please do not unplug during its operation.

### 13.2. Problem appearance

When CSE-6100 malfunctions, you promptly shall refer to “Problem Solving”. In case of continuous problem occurrence, please contact Customer Service Team of CODESQUARE or retail store where you purchased.

### 13.3. Frequent Problem Solving

#### **(Q1) Status Signal LED isn't Turned-on while it is running.**

(A1) This phenomenon occurs because of problems on its LED or CSE-6100's body. You should check it power supply and if this symptom keep occurring please contact the store you purchased

#### **(Q2) Lighting LED keep OFF even after trigger signal.**

(A2) You shall check whether External Lighting LED is On in system setting.

(A2) It could be LED Light problem. Please contact Customer Service team or Retail Store you purchased.

#### **(Q3) Barcode data are not transmitted to applied program while you use applied program interface function.**

(A3) Please check the setting status of applied program.

(A3) Please check whether the designated applied programs are well functioning on the window in the Applied Program Setting.

#### **(Q4) Cannot recognize barcode.**

(A4) You shall check whether decoding mode is “On” in the detailed Barcode Setting menu.

(A4) You shall check whether any dirt or object is on the surface of window. If yes, please remove it by soft towel.

(A4) When you hit F2 key after F1(Scan & Decoding) captured image of barcode is shown on the screen immediately. And, you have to check whether image condition is possible to be recognized.

#### **(Q5) Result Value of Barcode is not transmitted well**

(A5)It is the problem on CSE-6100 setting. Especially check the items related to Start/Stop setting.

#### **(Q6) Decoding result of 1D is transmitted without Start & Stop Code.**

(A6)It is the same case as code 39 shall be transmitted as “\*1234\*” but only “1234” is transmitted.

To solve this problem, CSE-6100 setting must be modified. In terms of Code 39, select “YES” for “Text Transmission Start/Stop” in the “Option”.

## 14. Interface cable for SDK

### 14.1. CSE-6100™-RS232C

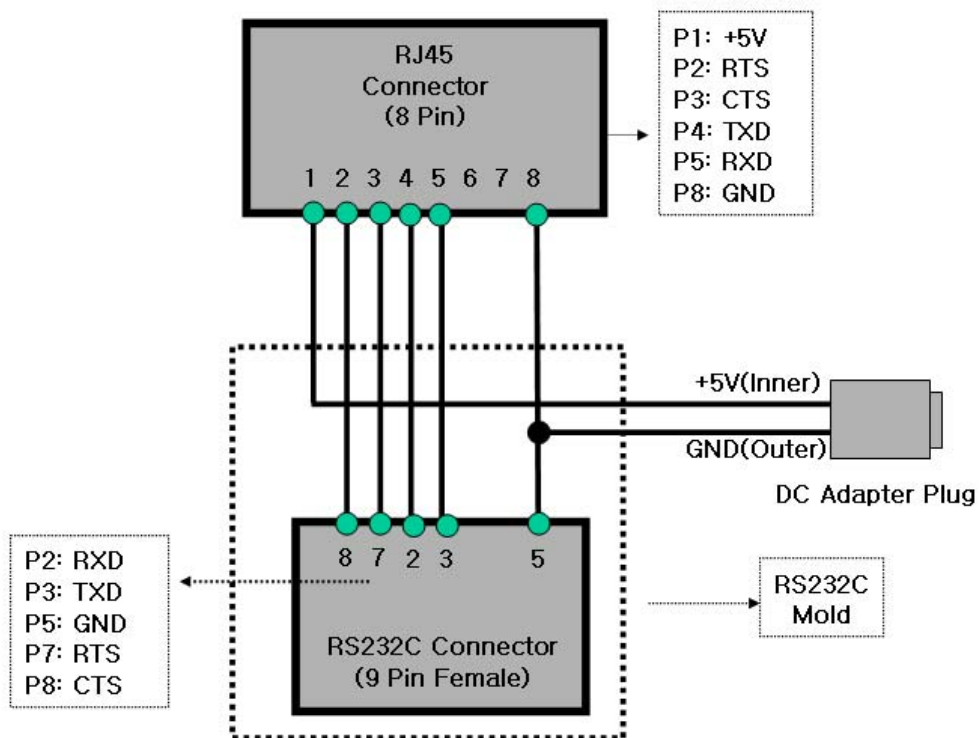
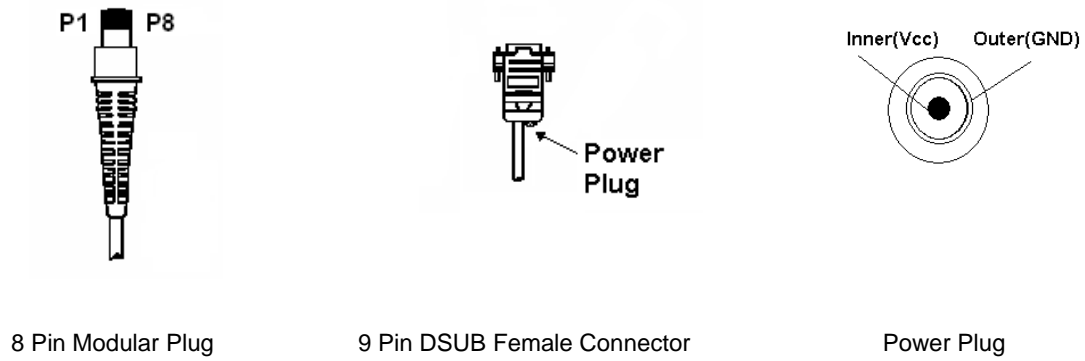



## 14.2. CSE-6100™-USB/HID

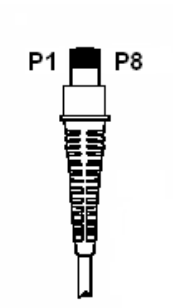

8 Pin Modular Plug



USB-A Connector

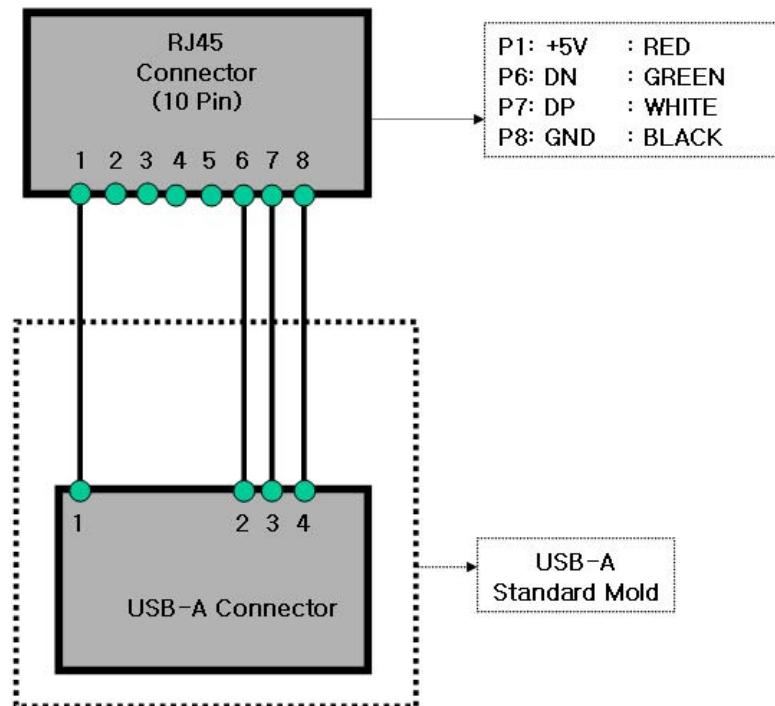

## 15. Host interface for SDK (RS232C / USB)

### RS232C Interface (DSUB 9 pin, Male)

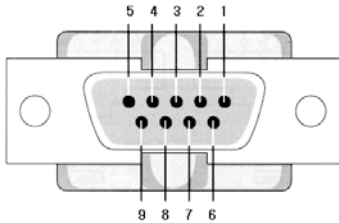

Pin	Name	Description
2	RXD	Receive data
3	TXD	Transmit data
5	GND	Ground
7	RTS	Request to Send
8	CTS	Clear to Send
9	SG	Signal Ground

### USB Interface



Pin	Name	Description
1	VBUS	+5 VDC
2	DN	Data-
3	DP	Data+
4	GND	Signal Ground

### RS232C Connection Diagram (Standard)

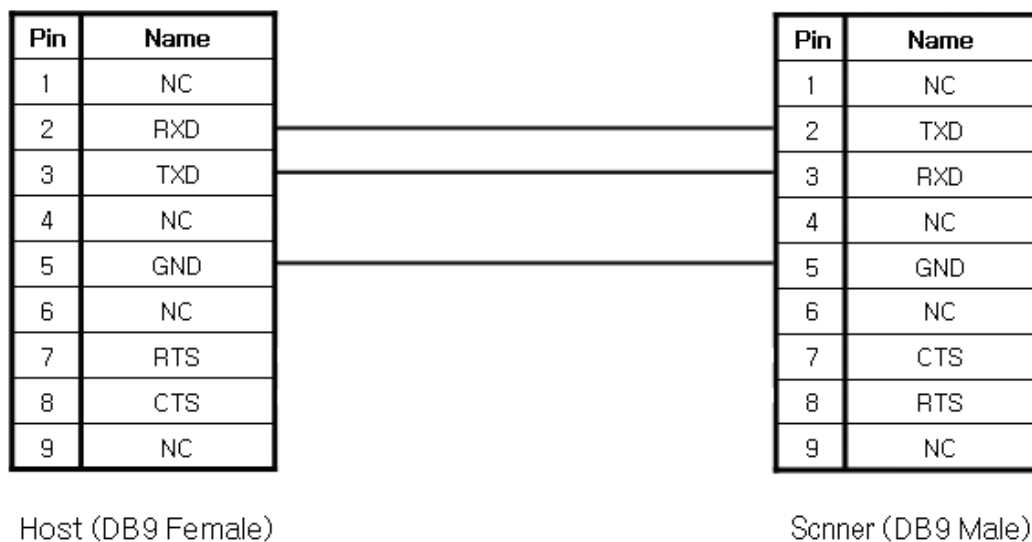

### RS232C Connection Diagram (RTS/CTS Control)

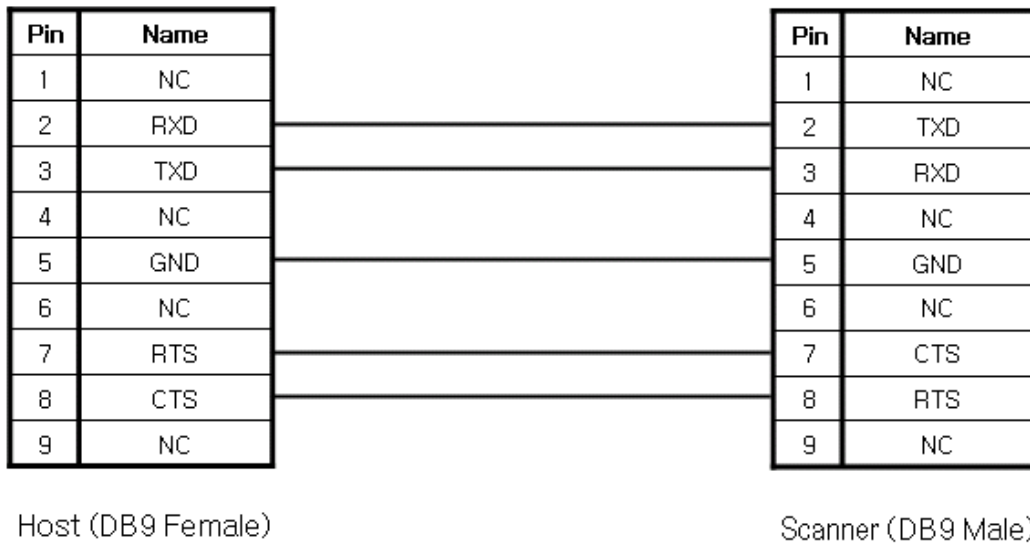

### USB D+/D- circuit

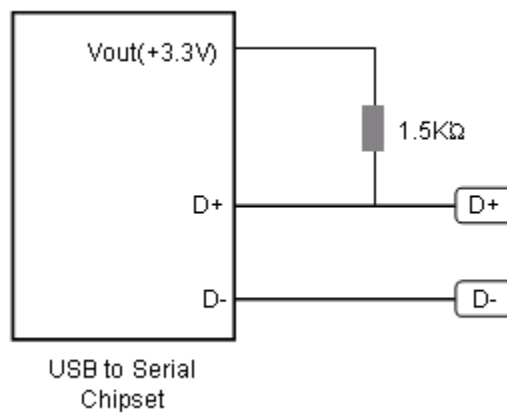

## 16. FPC Connector Signal Descriptions

Pin	Signal Name	Description	Remark
1	GND	Signal Ground	
2	GND	Signal Ground	
3	EXT-TRIGGER	External Trigger Input, Active Low	Pull-up 4.7KOhm, TTL Input
4	CLED1	Green LED enable signal	Good / Ready Signal, TTL Output
5	CLED0	Red LED enable signal	NG / Ready Signal, TTL Output
6	BUZZEROUT	BUZZER Output signal	TTL Output
7	nRTS0	RS232C Request To Send control signal	TTL Output
8	nCTS0	RS232C Clear To Send control signal	TTL Input
9	HTXD0	RS232C Transmit Signal	TTL Output
10	HRXD0	RS232C Receive Signal	TTL Input
11	VCC	VCC, +3.3V	±5%
12	VCC	VCC, +3.3V	±5%

## 17. Engine & SDK Drawing

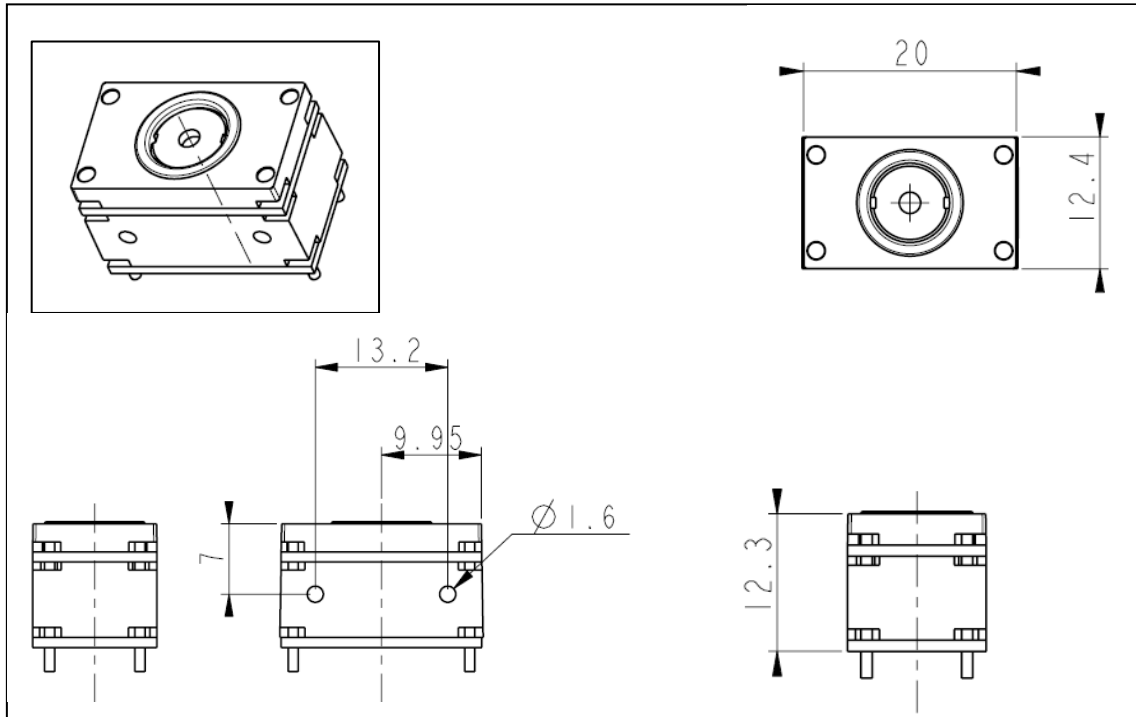

# 18. SDK Schematic Diagram

